

A diver in a blue wetsuit and mask is shown underwater, holding a large, long fish vertically. The background is a clear blue ocean. The text 'CATALOGUE 2025' is overlaid in large white letters.

CATALOGUE 2025



MADE IN ITALY

ERMES

◆	Descrizioni e istruzioni	pag 03-09	◆	Description and instruction	pag 03-09
◆	Kit arbaleti classici,inverter	pag 10-14	◆	Kit Spearfishing	pag 10-14
◆	Fusti alluminio	pag 15	◆	Barrel	pag 15
◆	Fusti Carbonio osso di seppia	pag 16-18	◆	Carbon barrel cuttlefish	pag 16-18
◆	Manici,ricambi ed accessori	pag 19-23	◆	Handles and spare parts	pag 19-23
◆	Testate	pag 24-28	◆	Muzzles	pag 24-28
◆	Elastici	pag 29	◆	Bands	pag 29
◆	Attacco rapido mulinello	pag 30	◆	Quick release reel	pag 30
◆	Mulinelli	pag 31-37	◆	Reels	pag 31-37
◆	Staffe telecamera	pag 38-40	◆	Brackets camera	pag 38-40
◆	Richiami	pag 41	◆	Call fish	pag 41
◆	Meccanismi	pag 42-46	◆	Triggers mechanism	pag 42-46
◆	Bozzelli sistemi inverter	pag 47	◆	Invert system block	pag 47
◆	Kit roller per legni	pag 48	◆	Kit roller wood	pag 48
◆	Pulegge	pag 49	◆	Pulleys	pag 49
◆	Stopper,sponde, assi	pag 50	◆	Stopper,bank, axis	pag 50
◆	Ganci, else, guidafile, fissaggio	pag 51-52	◆	Hook, Hilt, Guide Line, Fixing	pag 51-52
◆	Viti , spine, fissaggio	pag 53	◆	Accessories ,Screw, pin	pag 53
◆	Coltelli	pag 54-56	◆	Eagles	pag 54-56
◆	Cordine , Monofilamento	pag 57-58	◆	Line , Monofilament	pag 57-58
◆	Maschere, tubi	pag 59-63	◆	Mask, tube	pag 59-63
◆	Pinne	pag 64	◆	Fins	pag 64
◆	Torce	pag 65	◆	Flashlight	pag 65

THE BEGINNING

Ermes è una azienda artigianale nata nel Sud Italia dedicata alla progettazione ed alla costruzione di accessori per la pesca subacquea. Tutti i nostri prodotti sono progettati in casa, con una cura maniacale del disegno e della funzionalità, tante le idee che abbiamo sviluppato nei circa 20 anni di attività, molte sono le innovazioni apportate dai nostri progetti, tutte portano la firma di Mario Patruno l ideatore di tutti i nostri prodotti destinati ai migliori costruttori di attrezzature professionali per la pesca subacquea.

Moltissimi dei nostri prodotti sono stati progettati ascoltando i consigli degli utilizzatori, siamo pronti a confrontarci con i nostri clienti ed ascoltare anche le esigenze dei singoli utilizzatori.

Siamo orgogliosi di essere il punto di riferimento per le numerose piccole e medie aziende del settore, contribuendo al loro successo.

Ermes is an artisan company born in Southern Italy, dedicated to the design and construction of spearfishing accessories. All our products are designed in house, with an obsessive attention to design and functionality, so many ideas we have developed in about 20 years of activity, many are the innovations brought by our projects. All products intended for the best professional spearfishing equipment manufacturers and have Mario Patruno signature .

Many of our products have been designed listening to the advice of end users, we are ready to confront our customers and also listen to the individual user's needs.

We are proud to be the point of reference for the numerous small and medium-sized companies in the sector, contributing to

SERVICES

Offriamo servizi di consulenza e progettazione, ed eventuale costruzione del prodotto finito, tutto con i migliori materiali, Acciaio inox aisi 316, Titanio, Super Leghe, vari tipi di plastiche, Pom, Arnite, Nylon ecc. con tecnologie diverse a seconda delle destinazioni di uso, MIM, taglio EDM, taglio e saldatura laser, lavorazioni CNC, iniezioni plastiche, tutto è possibile soltanto consultateci, troveremo la soluzione adatta per Voi.

We offer consulting and design services, and possible construction of the finished product, all with the best materials, AISI 316 stainless steel, Titanium, Super Alloys, various types of plastics, Pom, Arnite, Nylon, etc. with different technologies depending on the intended use, MIM, EDM cutting, laser cutting and welding, CNC machining, plastic injections, everything is possible only ask us, we will find the right solution for you.

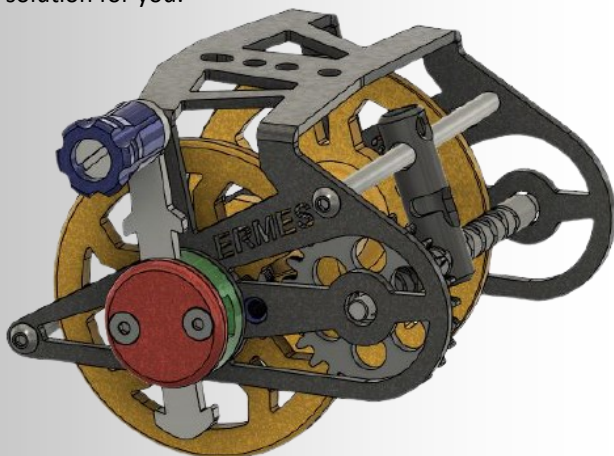

Avatar è un Divinità che scende sulla terra nella sua forma mortale, in grado di reincarnarsi in vari avatar, siamo gli dei della pesca subacquea , selezionamo con cura l arbalete perchè sarà il nostro AVATAR divino !!!

Avatar is a deity who descends to Earth in their mortal form, capable of reincarnating into various avatars. We are the gods of underwater fishing, carefully choosing the harpoon, as it will be our divine AVATAR! Designed by sea enthusiasts and those who turn their ideas into



- ◆ **Corpo Impugnatura in Nylon caricato vetro con anello di ancoraggio, e nervature ergonomiche ambidestre.**
- ◆ **Due sedi O ring di montaggio; scelta della sede a seconda del tubo se da 26 o 26.5.**
- ◆ **Manico in puro silicone con differenti colori, Bianco, Rosso vino, Rosso, Verde scuro, Verde fluoro, BlueNavy, Azzurro, Nero.**
- ◆ **Sicura Quicly safety a leva , ubicazione comoda per un rapido azionamento .**
- ◆ **Predisposizioni per attacco mulinello verticale o richiamo direttamente sull'elsa.**
- ◆ **Gancio e fori per sistemi inverter.**
- ◆ **Supporto ergonomico destro di serie.**
- ◆ **2 fori di predisposizione per attacco Staffa telecamera Revolution o Richiamo Siren di serie.**
- ◆ **Meccanismo con sistema doppio roller interamente realizzato in acciaio inox, grilletto ergonomico e sgancia sagola arrotondato (non taglia la sagola) con montaggio a destra o sinistra.**
- ◆ **Tubo in alluminio con rinforzi inferiori in lega strutturale 6061T6, colori rosso, e nero, misure 75, 82, 90, 100, 110, 120.,Inserto guida asta in plastica , vari colori.**
- ◆ **Testata predisposta per 2 elastici con predisposizione porta zavorra interno a seconda del modello.**
- ◆ **Testata Formula per sistemi inverter a seconda del modello.**
- ◆ **Tubo in Carbonio; opzionale.**
- ◆ **Supporto posteriore in acciaio per staffa telecamera Revolution; opzionale.**
- ◆ **Staffa Telecamera Revolution; opzionale.**
- ◆ **Mulinello Verticale ; opzionale nei modelli Colibri, Falco, Leonardo.**
- ◆ **Mulinello orizzontale nei modelli Sula, Albatros ; opzionale**
- ◆ **Handle body in glass reinforced nylon with anchor ring, and ergonomic ambidextrous ribs.**
- ◆ **Two O-ring mounting seats; choice of seat depending on the barrel if 26 or 26.5 mm.**
- ◆ **Pure silicone handle with different colors, White, Wine Red, Red, Dark Green ,Navy Blue, Sky Blue ,Black.**
- ◆ **Quickly safety lever, convenient location for quick operation.**
- ◆ **Arrangements for vertical reel attachment or call fish directly on the hilt.**
- ◆ **Hook and holes for inverter systems.**
- ◆ **Right ergonomic support as standard.**
- ◆ **2 Holes for support for Revolution camera bracket or Siren caller as standard.**
- ◆ **Mechanism with double roller system entirely made of stainless steel, ergonomic trigger and rounded line release (does not cut the line) with right or left mounting.**
- ◆ **Aluminum barrel with bottom reinforcements in structural alloy 6061T6, red and black colors, sizes 75, 82, 90, 100, 110, 120. Plastic insert guide shaft in various colors.**
- ◆ **Muzzle designed for 2 rubber bands with internal ballast holder, according to the model.**
- ◆ **Formula muzzles for inverter system unit, depending on the model.**
- ◆ **Rear steel support for Revolution camera bracket, optional.**
- ◆ **Optional carbon barrel.**
- ◆ **Optional; Bracket camera Revolution**
- ◆ **Optional Vertical Reel Colibri, Falco, Leonardo models.**





To correctly install the O-ring, follow these instructions:

1. Measure the internal diameter of the pipe.
2. If the internal diameter is ***26 mm***, position the O-ring in the ***second seat*** (refer to the figure).
3. If the internal diameter is ***26.5 mm***, position the O-ring in the ***first seat***.

Ensure that the O-ring is securely placed in the designated seat before installing the handle into the pipe. This will help create an effective seal.

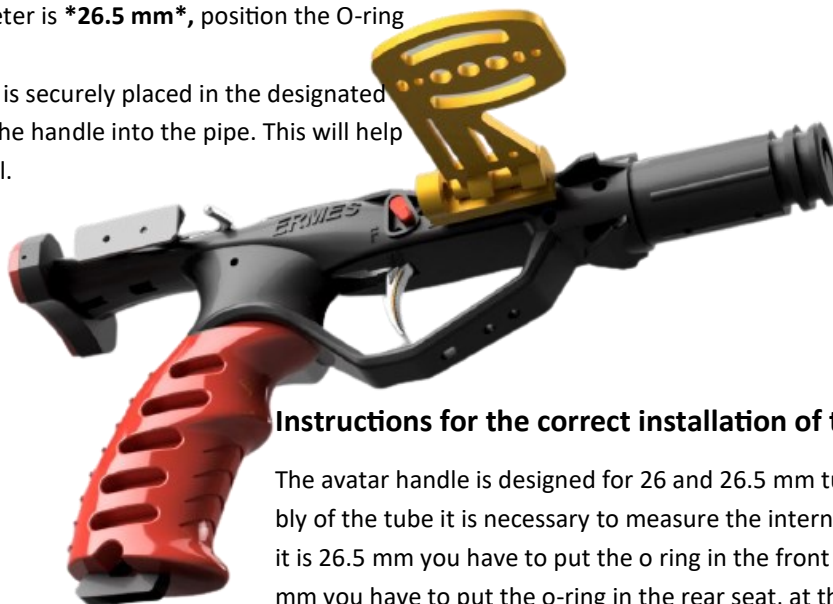

Instructions for the correct installation of the handle

The avatar handle is designed for 26 and 26.5 mm tubes, for the correct assembly of the tube it is necessary to measure the internal diameter of your tube, if it is 26.5 mm you have to put the o ring in the front seat, if the your tube is 26 mm you have to put the o-ring in the rear seat, at the same time you have to file the 6 spokes of the front part of the handle to reduce the overall dimensions from 26.5 to 26 mm.

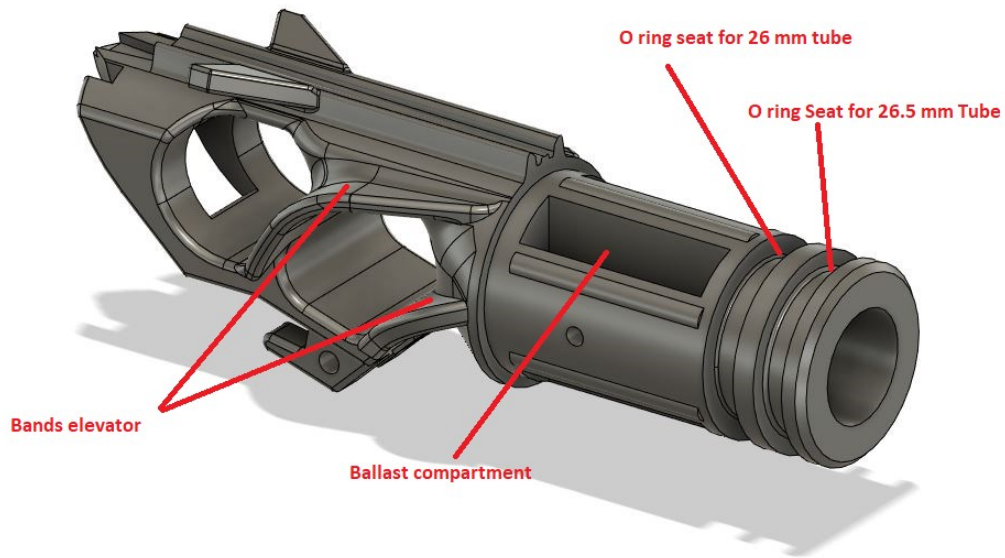

Instructions for the correct installation in the tube

The avatar handle is designed for 26 and 26.5 mm tubes, for the correct assembly of the tube it is necessary to measure the internal diameter of your tube, if it is 26.5 mm you have to put the o ring in the front seat, if the your tube is 26 mm

- ◆ L'impugnatura e le testate Avatar sono adattabili a tutti i tubi con diametro interno da 26 a 26,5 mm.

Bisogna tagliare le parti in eccesso (i raggi presenti sia nel manico che nella testata) per adattarlo al tuo tubo, tutti i tubi Ermes in alluminio hanno un diametro interno di 26,5 mm e tutti i tubi in carbonio Ermes hanno un diametro interno di 26 mm ed un offset per il guida asta di circa 2.7 mm, si consiglia di non forzare l'accoppiamento dei tubi in carbonio e di non utilizzare gli o ring, ma i tappi in dotazione. SE si utilizzano gli o ring per sigillare il tubo, questo deve essere posizionato nella corretta sede come mostrato in figura. Non siamo responsabili per danni causati da un montaggio errato.

- ◆ The Avatar handle and muzzles are adaptable to all tubes with an internal diameter of 26 to 26.5 mm.

You have to cut the excess parts (the spokes in both the handle and the muzzle) to adapt it to your tube, all Ermes aluminum tubes have an internal diameter of 26.5 mm

and all Ermes carbon tubes have an internal diameter of 26 mm, offset for guide shaft around 2.7 mm, it is advisable not to force the coupling of the carbon tubes and possibly and not to use the o rings, but the caps supplied.

IF you use O-rings to seal the pipe, it must be positioned in the correct location as shown in the figure

We are not responsible for damage caused by incorrect assembly.

- ◆ El mango y los cabezones Avatar son adaptables a todos los tubos con un diámetro interno de 26 a 26,5 mm.

Tienes que cortar las piezas sobrantes (los radios tanto en la empuñadura como en el cabezon) para adaptarlo a tu tubo, todos los tubos de aluminio Ermes tienen un diámetro interior de 26,5 mm

y todos los tubos de carbono Ermes tienen un diámetro interior de 26 mm, se aconseja no forzar el acoplamiento de los tubos de carbono y, en su caso, no utilizar las juntas tóricas, sino los tapones suministrados.

Si se utilizan juntas tóricas para sellar los tubos, debe colocarse en la ubicación correcta como se muestra en la figura

No nos hacemos responsables de los daños causados por un montaje incorrecto.

- ◆ Les poignées et têtes avatar sont adaptables à tous les tubes de diamètre intérieur de 26 à 26,5mm.

Vous devez couper les excès pour les adapter à vos tubes, tout les tubes ermes aluminium font 26,5mm de diamètre intérieur.

Tout les tubes carbone font 26mm de diamètre intérieur, nous vous recommandons de ne pas forcer lors de l'assemblage de vos tubes. Il est possible de supprimé les joints d'étanchéité de la poignée grâce aux bouchons d'étanchéité fournit avec les fûts. Si vous décidez d'utiliser les joints d'étanchéité veillez à les insérer dans la gorge prévu pour le diamètre de votre tube comme illustré par la figure ci dessous. Vous êtes responsable de tout dommage causer par un mauvais assemblage.

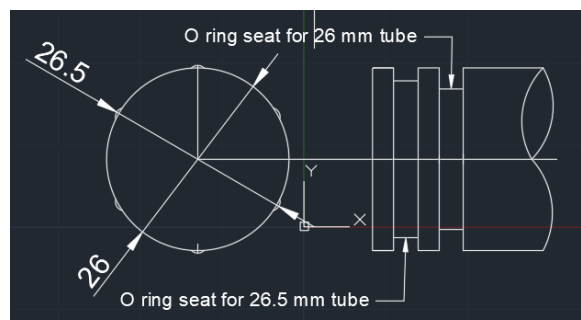

-----WARNING-----

Avatar handle and Muzzles are adaptable for all tube with inner diameter from 26 to 26.5 mm
you have to cut the excess parts to adapt it to your tube, all aluminum tube Ermes are 26.5 mm inner diameter
and all carbon tube Ermes are 26 mm inner diameter , we recommend not forcing the coupling of the carbon tubes and possibly not using the o rings, but the caps supplied .
If you use the o rings to seal the pipe, it must be placed in the correct seat as shown in the figure
We are not responsible for damage caused by incorrect assembly

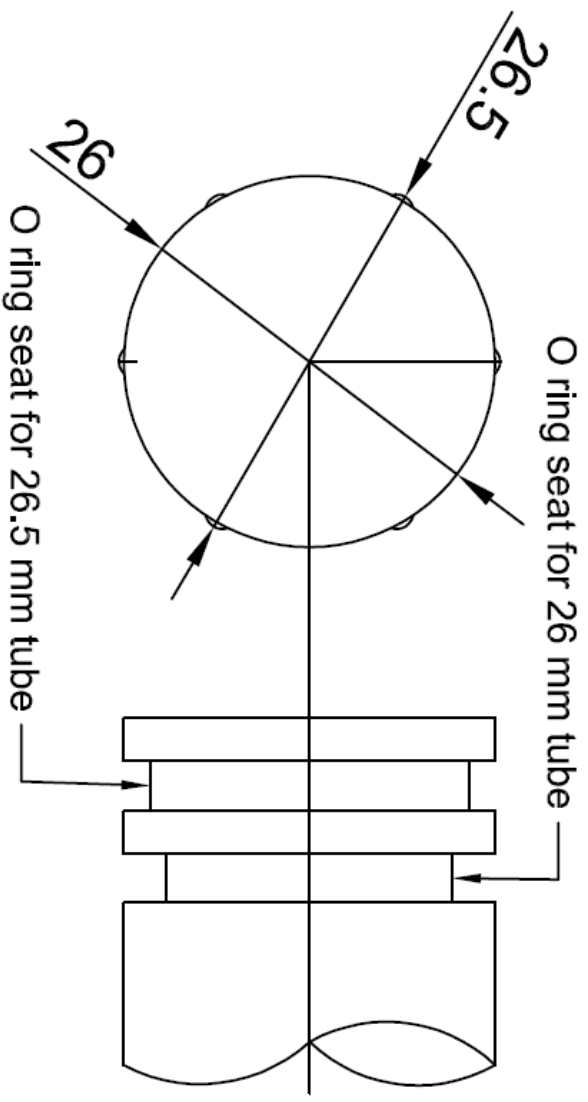

AVATAR KIT SPEARGUN ALUMINIUM

Available handle colors: Black, white, red, and blue, which you can combine with the silicone parts available in various colors. Aluminum tube in black and red, and Muzzle Avatar . Shaft not included

Colori disponibili per l'impugnatura: nero, bianco, rosso e blu, che puoi combinare con le parti in silicone disponibili in vari colori. Tubo in alluminio nero e rosso, e testata avatar . Asta non inclusa

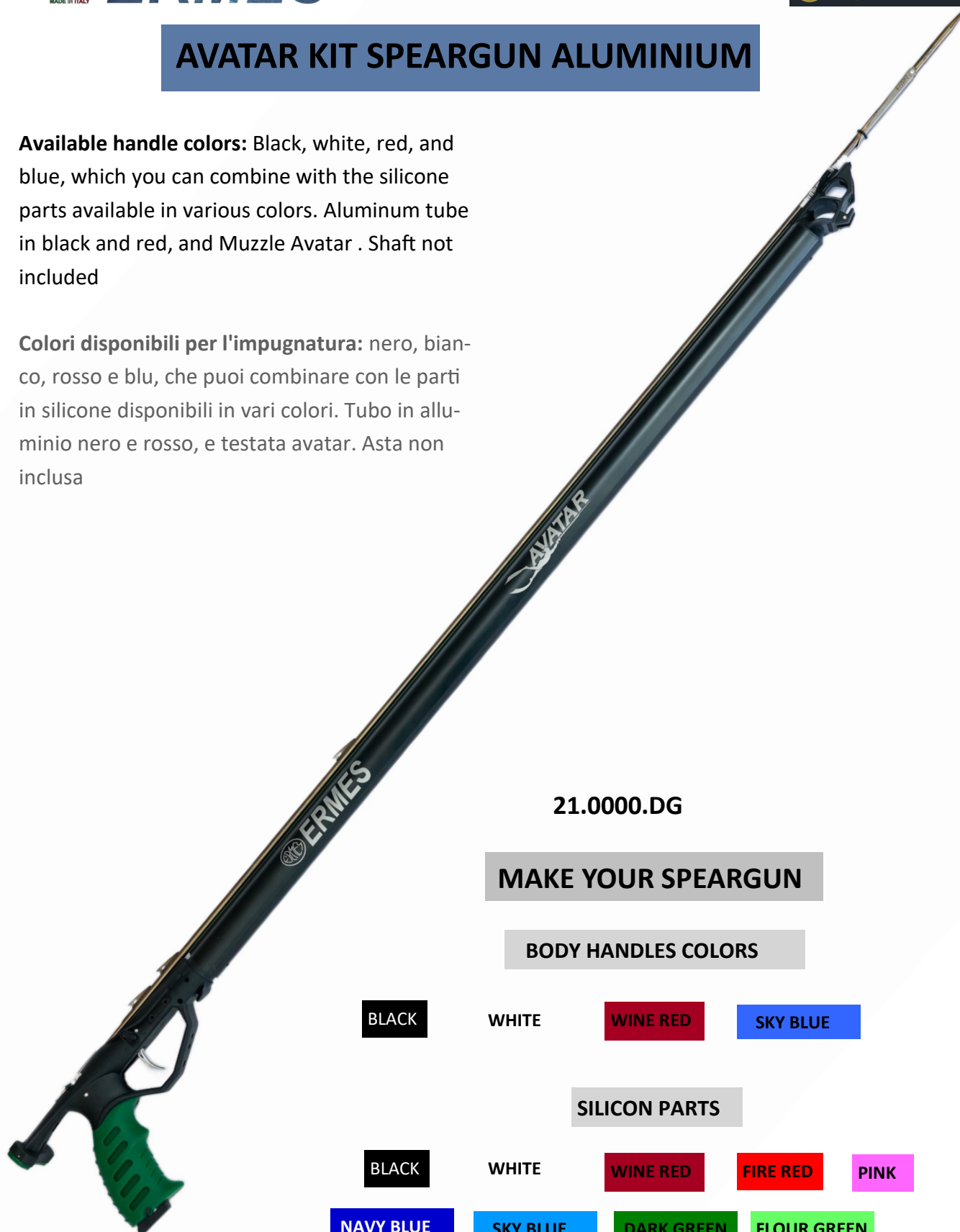

21.000.DG

MAKE YOUR SPEARGUN

BODY HANDLES COLORS

BLACK

WHITE

WINE RED

SKY BLUE

SILICON PARTS

BLACK

WHITE

WINE RED

FIRE RED

PINK

NAVY BLUE

SKY BLUE

DARK GREEN

FLOUR GREEN

SIZE BARREL

75

85

90

100

110

120

AVATAR KIT SPEARGUN ALUMINIUM 3 BANDS

Available handle colors: Black, white, red, and blue, which you can combine with the silicone parts available in various colors. Aluminum tube in black and red, and Muzzle 3 bands sliding or ceramic options. Shaft not included

Colori disponibili per l'impugnatura: nero, bianco, rosso e blu, che puoi combinare con le parti in silicone disponibili in vari colori. Tubo in alluminio nero e rosso, e testata versione sliding e in ceramica.

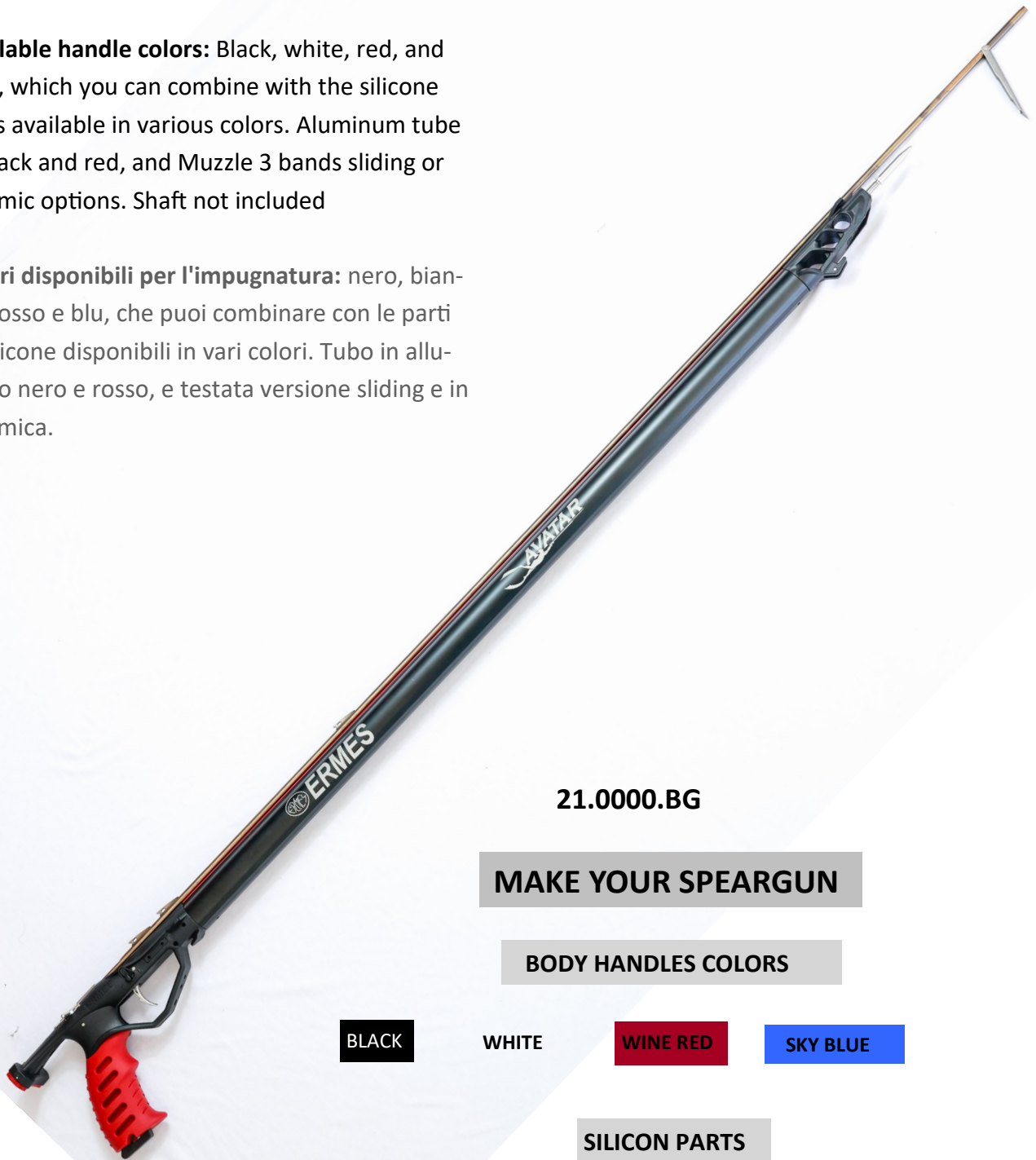

21.000.BG

MAKE YOUR SPEARGUN

BODY HANDLES COLORS

BLACK

WHITE

WINE RED

SKY BLUE

SILICON PARTS

BLACK

WHITE

WINE RED

FIRE RED

PINK

SKY BLUE

DARK GREEN

FLOUR GREEN

SIZE BARREL

75

85

90

100

110

120

AVATAR KIT SPEARGUN ALUMINIUM FORMULA

Available handle colors: Black, white, red, and blue, which you can combine with the silicone parts available in various colors. Aluminum tube in black and red, and Muzzle formula sliding or ceramic options. Shaft not included

Colori disponibili per l'impugnatura: nero, bianco, rosso e blu, che puoi combinare con le parti in silicone disponibili in vari colori. Tubo in alluminio nero e rosso, e testata versione sliding e in ceramica.

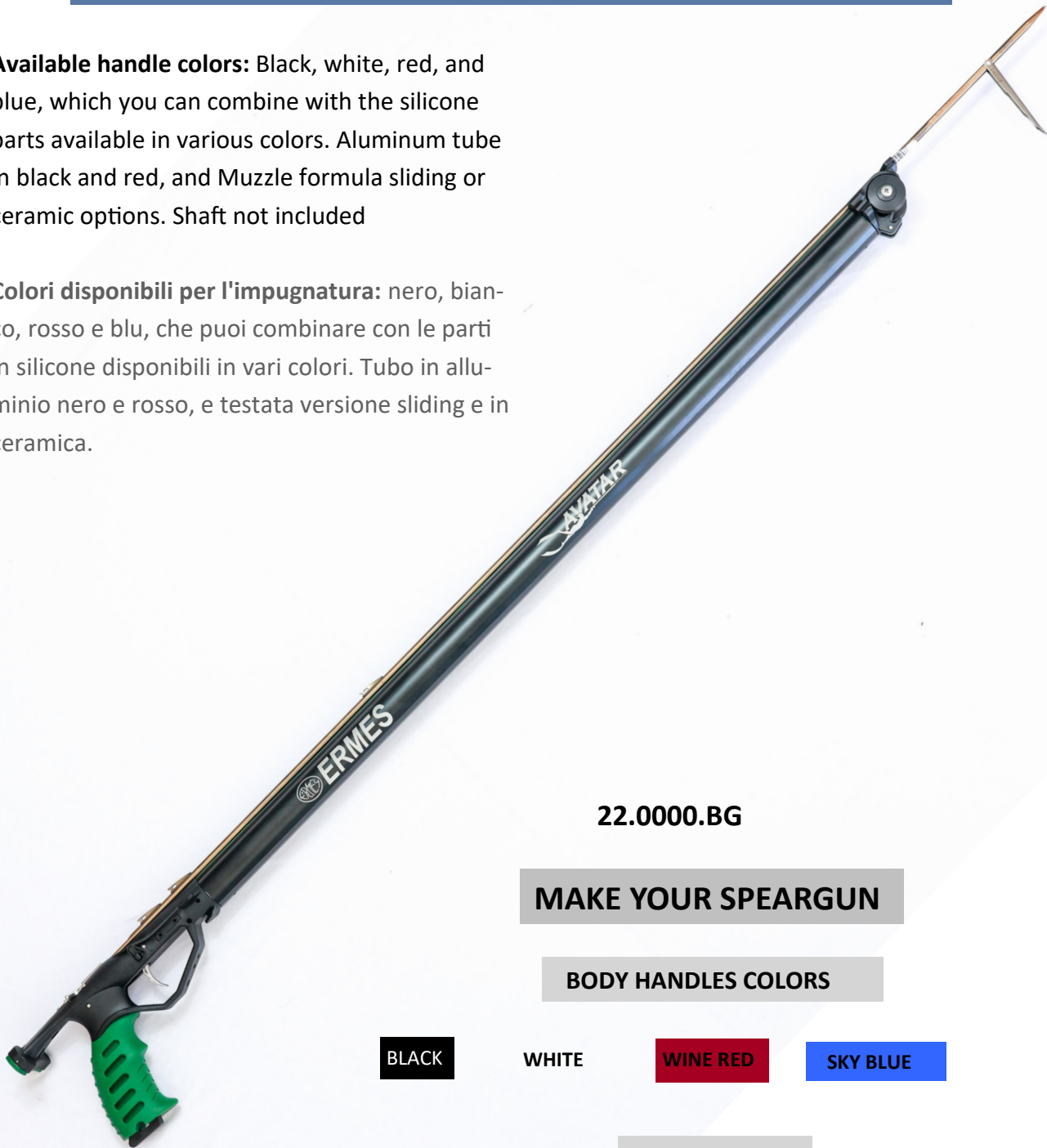

22.000.BG

MAKE YOUR SPEARGUN

BODY HANDLES COLORS

BLACK

WHITE

WINE RED

SKY BLUE

SILICON PARTS

BLACK

WHITE

WINE RED

FIRE RED

PINK

SKY BLUE

DARK GREEN

FLOUR GREEN

SIZE BARREL

75

85

90

100

110

120



AVATAR KIT SPEARGUN ALUMINIUM ROLLER

Available handle colors: Black, white, red, and blue, which you can combine with the silicone parts available in various colors. Aluminum tube in black and red, and Muzzle Roller sliding or ceramic options. Shaft not included

Colori disponibili per l'impugnatura: nero, bianco, rosso e blu, che puoi combinare con le parti in silicone disponibili in vari colori. Tubo in alluminio nero e rosso, e testata versione sliding e in ceramica. Shaft not included

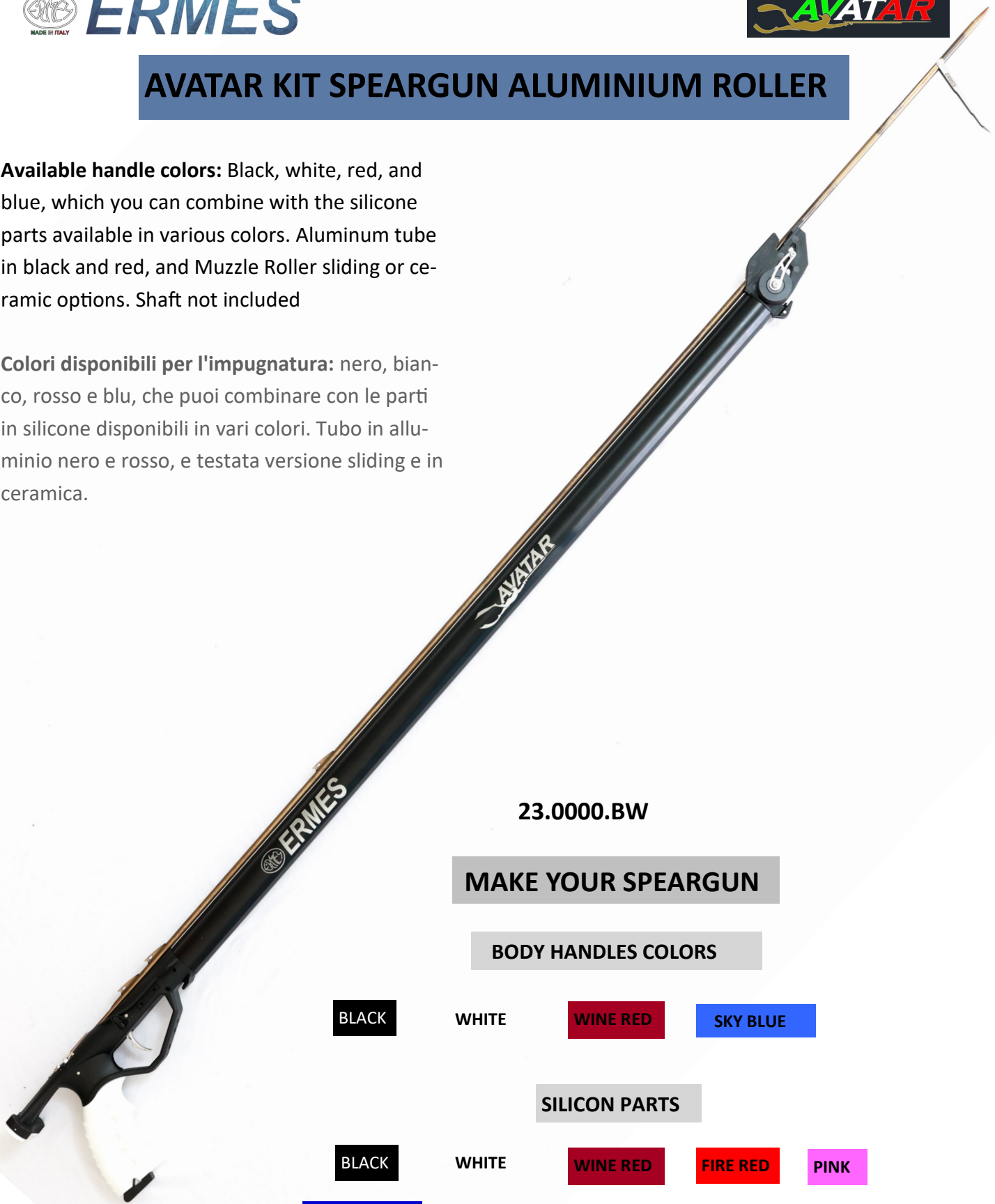

23.0000.BW

MAKE YOUR SPEARGUN

BODY HANDLES COLORS

BLACK

WHITE

WINE RED

SKY BLUE

SILICON PARTS

BLACK

WHITE

WINE RED

FIRE RED

PINK

NAVY BLUE

SKY BLUE

DARK GREEN

FLOUR GREEN

SIZE BARREL

75

85

90

100

110

120

AVATAR KIT SPEARGUN ALUMINIUM DOUBLE ROLLER

Available handle colors: Black, white, red, and blue, which you can combine with the silicone parts available in various colors. Aluminum tube in black and red, and Muzzle double roller sliding or ceramic options. Shaft not included

Colori disponibili per l'impugnatura: nero, bianco, rosso e blu, che puoi combinare con le parti in silicone disponibili in vari colori. Tubo in alluminio nero e rosso, e testata versione sliding e in ceramica. Shaft not included

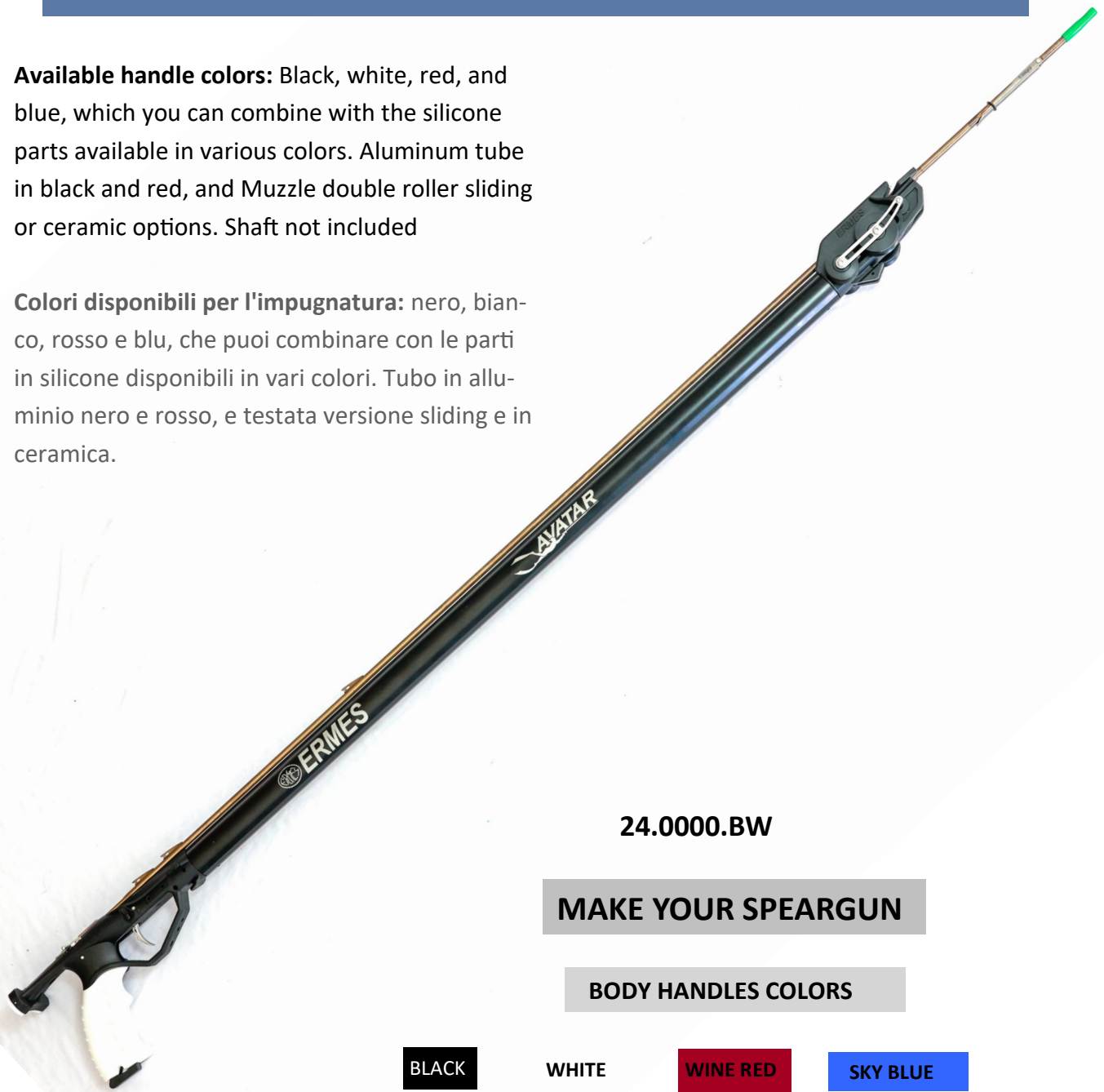

24.0000.BW

MAKE YOUR SPEARGUN

BODY HANDLES COLORS

BLACK

WHITE

WINE RED

SKY BLUE

SILICON PARTS

BLACK

WHITE

WINE RED

FIRE RED

PINK

SKY BLUE

DARK GREEN

FLOUR GREEN

SIZE BARREL

75

85

90

100

110

120

ALUMINUM TUBE D 26.5mm

Tubo in alluminio strutturale 6061T6, con pista guida asta in plastica , per diminuire la superficie di scorrimento, le nervature inferiori contribuiscono a rendere il tutto piu robusto.

6061T6 structural aluminum tube, with plastic guide track, to reduce the sliding surface, the lower ribs contribute to making the whole more strong.

CODICE	MODEL
<u>21.A075.AB</u>	Barrel Aluminium Avatar Black 75
<u>21.A075.AR</u>	Barrel Aluminium Avatar Red 75
<u>21.A082.AB</u>	Barrel Aluminium Avatar Black 82
<u>21.A082.AR</u>	Barrel Aluminium Avatar Red 82
<u>21.A090.AB</u>	Barrel Aluminium Avatar Black 90
<u>21.A090.AR</u>	Barrel Aluminium Avatar Red 90
<u>21.A100.AB</u>	Barrel Aluminium Avatar Black 100
<u>21.A100.AR</u>	Barrel Aluminium Avatar Red 100
<u>21.A110.AB</u>	Barrel Aluminium Avatar Black 110
<u>21.A110.AR</u>	Barrel Aluminium Avatar Red 110
<u>21.A120.AB</u>	Barrel Aluminium Avatar Black 120
<u>21.A120.AR</u>	Barrel Aluminium Avatar Red 120



CARBON PRO 78 Cuttlefish 26mm

Tubo In Carbonio 100% twill ricavato da stampo. Diametro interno 26 mm esterno 30.4, altezza guida asta standard 26.5 mm. Larghezza massima 78 mm .

Lavorazione ad alta temperatura priva di difetti. Tubo vuoto per una maggiore galleggiabilità fornito con tappi in silicone. Misure standard da 75 a 140 cm, possibile personalizzare misura e marchio per grandi richieste. Disegni 100% idrodinamici

Molded 100% twill carbon tube. Internal diameter 26 mm external 30.4, Guide shaft height 2.65 mm. Maximum width 78mm.

Defect-free high-temperature processing.

Vacuum tube for added buoyancy.

Supplied with silicone plugs.

Standard sizes from 75 to 140 cm, it is possible to customize the size and brand for large requests.

100% hydrodynamic designs.

CODICE	MODEL
<u>21.P075.00</u>	Carbon Pro Avatar 75
<u>21.P080.00</u>	Carbon Pro Avatar 80
<u>21.P085.00</u>	Carbon Pro Avatar 85
<u>21.P090.00</u>	Carbon Pro Avatar 90
<u>21.P095.00</u>	Carbon Pro Avatar 95
<u>21.P100.00</u>	Carbon Pro Avatar 100
<u>21.P105.00</u>	Carbon Pro Avatar 105
<u>21.P110.00</u>	Carbon Pro Avatar 110
<u>21.P115.00</u>	Carbon Pro Avatar 115
<u>21.P120.00</u>	Carbon Pro Avatar 120
<u>21.P125.00</u>	Carbon Pro Avatar 125
<u>21.P130.00</u>	Carbon Pro Avatar 130
<u>21.P135.00</u>	Carbon Pro Avatar 135
<u>21.P140.00</u>	Carbon Pro Avatar 140



CARBON EXTREME 88mm CUTTLEFISH

- ◆ Tubo In Carbonio 100% twill ricavato da stampo. Diametro interno 26 mm esterno 30.4, altezza guida asta standard 26.5 mm. Larghezza massima 88 mm .
 - ◆ Lavorazione ad alta temperatura priva di difetti.
 - ◆ Lavorazione a 3 scomparti per una maggiore leggerezza , robustezza e galleggiabilità
 - ◆ Misure standard da 90 a 140 cm, possibile personalizzare misura e marchio per grandi richieste .
 - ◆ Disegni 100% idrodinamici
 - ◆ Fornito con 2 tappi in silicone
-
- ◆ Molded 100% twill carbon tube. Internal diameter 26 mm external 30.4, standard rod guide height 26.5 mm. Maximum width 88mm.
 - ◆ Defect-free high-temperature processing.
 - ◆ Processing with 3 compartments for greater lightness, strength and buoyancy .
 - ◆ Standard sizes from 90 to 140 cm, it is possible to customize the size and brand for large requests.
 - ◆ 100% hydrodynamic designs
 - ◆ Supplied with 2 silicone caps

CODICE	MODEL
<u>21.X090.00</u>	<u>Carbon X Avatar 90</u>
<u>21.X095.00</u>	<u>Carbon X Avatar 95</u>
<u>21.X100.00</u>	<u>Carbon X Avatar 100</u>
<u>21.X105.00</u>	<u>Carbon X Avatar 105</u>
<u>21.X110.00</u>	<u>Carbon X Avatar 110</u>
<u>21.X115.00</u>	<u>Carbon X Avatar 115</u>
<u>21.X120.00</u>	<u>Carbon X Avatar 120</u>
<u>21.X125.00</u>	<u>Carbon X Avatar 125</u>
<u>21.X130.00</u>	<u>Carbon X Avatar 130</u>
<u>21.X135.00</u>	<u>Carbon X Avatar 135</u>
<u>21.X140.00</u>	<u>Carbon X Avatar 140</u>





CUSTOMIZABLE HANDLE OPTIONS:

A PALETTE OF COLORS FOR YOUR PERFECT COMBINATION !!

Il colore standard del corpo del manico è nero, ma sono disponibili anche altri colori, tra cui bianco, azzurro cielo e rosso vino. Per quanto riguarda il grip in silicone, offriamo diverse opzioni di colore, tra cui bianco, nero, rosa, rosso fuoco, rosso vino, azzurro cielo, blue navy, verde scuro e verde fluo. Per il pad load, i colori disponibili sono bianco, nero, rosso vino, blue navy e verde scuro. È possibile scegliere la combinazione di colori desiderata con un piccolo supplemento.

The standard color of the handle body is black, but we also have other available colors, including white, sky blue, and wine red. For the silicone grip, we offer options such as white, black, pink, fire red, wine red, sky blue, navy blue, dark green, and fluorescent green. As for the pad load, the available colors are white, black, wine red, navy blue, and dark green. You can choose the desired color combination with a small additional cost.



All configurations are possible. The standard handle body is black, but we also have white, red, wine, and Sky blue colors available upon request. This allows for a wide variety of combinations with the grip, which comes in various assorted colors including white, black, wine, dark green, navy blue, fire red, fluorescent green, light blue, and pink. In your order, next to the standard code for black color for the body, insert 'white' if you want white color, 'red wine' if you prefer red, and 'sky blue' if you choose sky blue. Thank you.



- ◆ **Meccanismo double roller con sgancia sagola integrato e grilletto anatomico**
- ◆ **Corpo in nylon caricato 30% fibra di vetro nei colori nero, bianco, blu, rosso vino.**
- ◆ **Fori e gancio per numerose configurazioni invert roller.**
- ◆ **Adatto per tubi da 26 e 26.5 mm**
- ◆ **Vano per bilanciamento con inserto estraibile porta supporto camera, e call fish.**
- ◆ **Sicurezza in posizione comoda per un rapido azionamento.**
- ◆ **Attacco posteriore per supporto camera.**
- ◆ **Appoggio sternale in comodo in silicone silicone vari colori.**
- ◆ **Manico anatomico in silicone nei colori bianco, nero, rosso vino, verde scuro, blue navy, rosso fuoco, azzurro, verde fluoro, rosa.**
- ◆ **Supporto removibile anatomico in nylon per un comodo grip.**
- ◆ **Double roller mechanism with integrated line release and anatomic trigger.**
- ◆ **Body in nylon with 30% glass fiber, black, white, blue, wine red colors.**
- ◆ **holes and hook for numerous invert roller configurations.**
- ◆ **Suitable for 26 and 26.5 mm tubes.**
- ◆ **Compartment for balancing with removable insert for camera support, and call fish.**
- ◆ **Safety in convenient position for quick operation.**
- ◆ **Rear attachment for camera support.**
- ◆ **Pad load in comfortable various colors silicon.**
- ◆ **Anatomic silicone handle in white, wine-red, dark green, navy blue, fire red, sky blue, fluoro green, pink colors.**
- ◆ **Right or left anatomical support in remova-**

SILICON HANDLE GRIP AVATAR

CODICE		COLOR
<u>21.0001.0W</u>	Grip	White
<u>21.0001.0B</u>	Grip	Black
<u>21.0001.WR</u>	Grip	Wine Red
<u>21.0001.DG</u>	Grip	Dark Green
<u>21.0001.NB</u>	Grip	Navy Blue



SILICON HANDLE GRIP PRO AVATAR

CODICE		COLOR
<u>21.1101.0W</u>	Grip Pro	White
<u>21.1101.0B</u>	Grip Pro	Black
<u>21.1101.FR</u>	Grip Pro	Fire-Red
<u>21.1101.FG</u>	Grip Pro	Fluore-Green
<u>21.1101.SB</u>	Grip Pro	Sky-Blue
<u>21.1101.OP</u>	Grip Pro	Pink



CODICE		COLOR
<u>21.1200.0W</u>	Pad Load	White
<u>21.1200.0B</u>	Pad Load	Black
<u>21.12.00.WR</u>	Pad Load	Wine-Red
<u>21.1200.DG</u>	Pad Load	Dark-Green
<u>21.1200.NB</u>	Pad Load	Navy-Blue

SILICON PAD LOAD AVATAR



CODICE		COLOR
<u>21.1201.0W</u>	Pad Load Pro	White
<u>21.1201.0B</u>	Pad Load Pro	Black
<u>21.12.01.FR</u>	Pad Load Pro	Fire-Red
<u>21.1201.FG</u>	Pad Load Pro	Fluore-Green
<u>21.1201.NB</u>	Pad Load Pro	SKY-Blue
<u>21.1201.OP</u>	Pad Load Pro	Pink



MODEL	CODICE
ERMES PLUG BARREL	21.2000.00



MODEL	CODICE
PLASTIC OGIVA	16.0010.00



	CODICE
<u>SAFETY</u>	<u>21.1300.00</u>
<u>ANATOMIC INSERT right</u>	<u>21.1700.10</u>
<u>ANATOMIC INSERT left</u>	<u>21.1700.10</u>
<u>ORING</u>	<u>21.2100.00</u>



TRIGGER AVATAR

Meccanismo leggero box da 1.5 mm, sgancia sagola piccolo e grilletto corto ergonomico, componenti in acciaio aisi 316 , Sistema Doppio Roller.

Light weight 1.5 mm box mechanism, small line release and short trigger, components in AISI 316 steel.

MODEL	CODICE	WEIGHT
<u>AVATAR DOUBLE ROLL</u>	<u>00.0013.00</u>	<u>92.00G</u>
<u>AVATAR DOUBLE ROLL GOLD</u>	<u>00.0013.01</u>	<u>92.00G</u>



MODEL**CODICE**

PULLEY INVERT SYSTEM

04.1805.10

**MODEL****CODICE**

QUICK RELEASE REEL

21.2000.00



AVATAR

Grazie alle 2 piste di sollevamento, gli elastici si predispongono quasi paralleli al fusto, aumentando la performance e la precisione del tiro. Internamente presenta 4 vani per la zavorra, con due sedi o ring a seconda che si voglia montare un tubo da 26, o 26.5 mm.

Thanks to the 2 lifting tracks, the bands are arranged almost parallel to the barrel, increasing the performance and accuracy of the shot. Internally it has 4 compartments for the ballast, it has two O-ring seats depending on whether you want to mount a 26 or 26.5 mm barrel.

MODEL	CODICE	WEIGHT
AVATAR	21.1800.00	34G



SHARK 3

Le 3 piste di sollevamento incanalano gli elastici e li predispongono paralleli al fusto aumentando la potenza e la precisione del del tiro. Nella punta è presente un foro filettato M6 , è possibile avvitare una punta (Tip Shark in vendita separatamente) per dissuadere ed allontanare eventuali squali o la si puo usare per bilanciare la punta del fucile aggiungendo una vite. Ha due sedi o ring a seconda che si voglia montare un tubo da 26, o 26.5 mm.

The 3 lifting tracks channel the bands and arrange them parallel to the barrel, increasing the power and accuracy of the shot. In the tip there is an M6 threaded hole, it is possible to screw a tip (Tip Shark-Sold separately) to dissuade and remove any sharks or it can be used to balance the tip of the speargun by adding a screw. It has two o-ring seats depending on whether you want to mount a 26 or 26.5 mm tube

MODEL	CODICE	WEIGHT
SHARK 3	21.1800.00	G
TIP SHARK 3	03.0407.00	G



FORMULA INVERT

Piccola , leggera, interamente costruita a cnc, presenta al centro gli attacchi per il sistema inverter, le pulegge da 30 mm , sono protette da una carenatura e possono ospitare cuscinetti ceramici ad alta velocita. Sono presenti due sedi o ring che la rendono idonea al montaggio di tubi da 26 o 26.5 mm.

Small, light, entirely CNC built, it has in the center the attacks for the inverter system, the 30 mm pulleys, are protected by a fairing and can accommodate high-speed ceramic bearings. There are two O-rings seats that make it suitable for mounting of 26 or 26.5 mm barrel.

MODEL	CODICE	WEIGHT
FORMULA INVERT SLIDING	03.0010.00	34G
FORMULA INVERT CERAMIC	03.0010.01	40G



ROLLER

Piccola , leggera, le pulegge da 28mm , sono protette da una carenatura in acciaio e possono ospitare cuscinetti ceramici ad alta velocita. Sono presenti due sedi o ring che la rendono idonea al montaggio di tubi da 26 o 26.5 mm.

Small, light, entirely CNC built, the 28 mm pulleys, are protected by a fairing and can accommodate high-speed ceramic bearings. There are two O-rings seats that make it suitable for mounting of 26 or 26.5 mm barrel.

MODEL	CODICE
<u>ROLLER SLIDING</u>	<u>03.0018.00</u>
<u>ROLLER CERAMIC</u>	<u>03.0018.01</u>



DOUBLE ROLLER

MODEL	CODICE
<u>DOUBLE ROLLER SLIDING</u>	<u>03.0011.00</u>
<u>DOUBLE ROLLER CERAMIC</u>	<u>03.0011.01</u>



ROLLER FIGHTER

Piccola , leggera, le pulegge da 28mm , carenatura integrata, gancio estraibile per avvolgimento del filo inferiore, possibilita fi avvolgimento del filo lateralmente, questo evita possibili inparruccamenti ,puo ospitare cuscinetti ceramici ad alta velocita. Sono presenti due sedi o ring che la rendono idonea al montaggio di tubi da 26 o 26.5 mm.

Small and lightweight, 28mm pulleys, integrated fairing, retractable hook for winding the line underneath, with the possibility of lateral line winding, which prevents possible tangles. It can accommodate high-speed ceramic bearings. There are two O-ring seats that make it suitable for

MODEL	CODICE	WEIGHT
ROLLER FIGHTER SLIDING	03.0012.00	
ROLLER FIGHTER CERAMIC	03.0012.01	





Prime Progressive

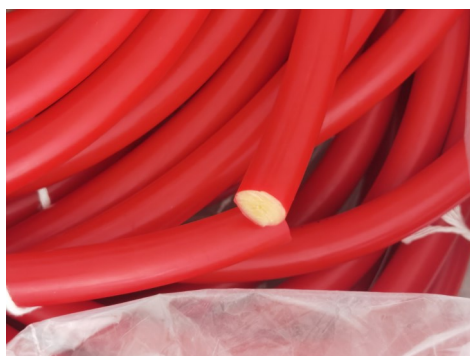

Elastico a contrazione progressiva, interno in puro caucciù ambra, foro interno da 1.5mm , colore rosso o nero che si adatta particolarmente ai fusti in alluminio nero ed ai fusti in carbonio. Progressive contraction rubber band, pure amber latex inside, 1.5mm internal hole, red or black color lining which particularly adapts to black aluminum and carbon barrels .

MODEL	COLOR	CODE	OD	ID
Prime Progressive	Red/Amber	15.1415.RA	14 mm	1.5 mm
Prime Progressive	Red/Amber	15.1615.RA	16 mm	1.5mm
Prime Progressive	Black/Amber	16.1630.RA	16 mm	3mm



QUICK RELEASE REEL

Con questo accessorio è possibile agganciare e sganciare rapidamente il mulinello dal nostro fucile Avatar, si può montare sia sul fusto che sull'elsa del manico. Funziona anche con i fucili in legno. E' composto da due parti, uno si aggancia al fucile e l'altro al mulinello con le apposite viti in dotazione. E' dotato di un pulsante di sicurezza, bisognerà premerlo per sganciare il mulinello.

With this accessory it is possible to quickly hook and unhook the reel from our Avatar speargun, it can be mounted both on the barrel and on the hilt of the handle. It also works with wooden rifles. It is made up of two parts, one attaches to the speargun and the other to the reel with the special screws supplied. It is equipped with a safety button, you will have to press it to release the reel.

MODEL

QUICK RELEASE REEL

CODICE

21.0002.00

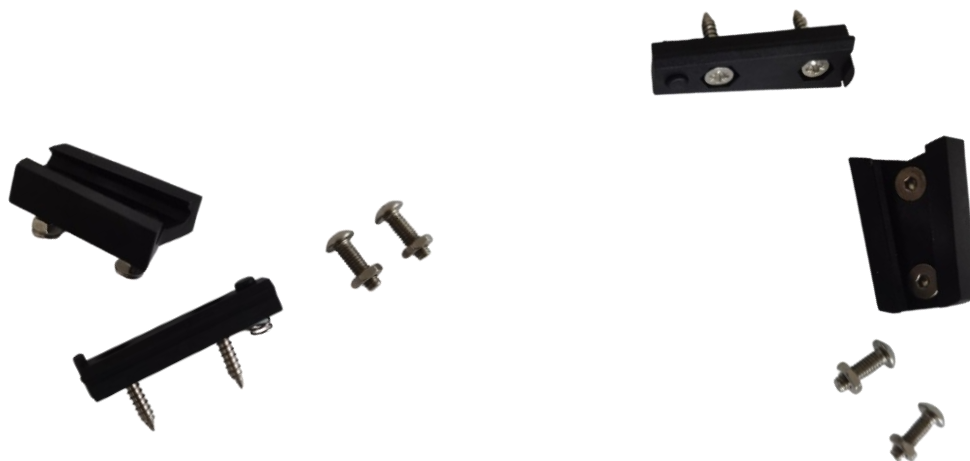

Produciamo due modelli, verticali e orizzontali, Alcuni modelli sono interamente prodotti a CNC ed utilizzando i migliori materiali, Nylon caricato con fibra di vetro, Pom C, acciaio inox aisi 316, e per le parti piane metalliche, acciaio ed a richiesta Titanio. La frizione per tutti i modelli è del tipo a scatti con funzionamento a sfera e ghiera filettata in metallo, il vantaggio è che si può dosare la forza, in modo tale da stancare il pesce.

La manopola di avvolgimento per i modelli orizzontali è estraibile, per i modelli verticale la maniglia di avvolgimento può essere estratta in 3 posizioni differenti ed il funzionamento è a sfera.

I modelli orizzontali comprendono il piccolo Sula, ed i più grandi Albatros, I modelli verticali spaziano dal piccolo Colibrì ai più grandi Leonardo, passando per i modelli Seagull e Falco.

I modelli Leonardo hanno un sistema automatico per il riavvolgimento del filo, funzione molto comoda che permette di avvolgere il filo velocemente ed ordinatamente.

We produce two models, vertical and horizontal. Some models are entirely CNC machined using the best materials: nylon reinforced with fiberglass, POM-C, stainless steel AISI 316, and for the flat metal parts, steel or titanium upon request. The drag system for all models is a stepped type with a ball-operated mechanism and a metal thread ring, allowing the force to be adjusted to tire out the fish.

The winding knob for the horizontal models is removable, while for the vertical models, the winding handle can be adjusted to three different positions, with a ball-operated mechanism.

The horizontal models include the small 'Sula' and the larger 'Albatros.' The vertical models range from the small 'Colibrì' to the larger 'Leonardo,' with intermediate models such as 'Seagull' and 'Falco.'

The 'Leonardo' models have an automatic line winding system, a very convenient feature that allows the line to be wound quickly and neatly.



Seagull

Mulinello verticale di media capienza, circa 45 metri di filo da 1.5 mm. Il robusto telaio in plastica lo rende leggero, pesa solo 100 grammi, integra nel telaio il sistema quick release, ottimale per i nostri manici Avatar, con questo sistema è possibile estrarre ed inserire rapidamente il mulinello, di serie nel sistema il pulsante di blocco che evita lo sgancio accidentale del mulinello, è possibile alloggiare sul telaio il richiamo call fish grazie ai due fori di predisposizione. Manopola frizione con inserto filettato in metallo e maniglia estraibile entrambe con funzionamento a sfera. Diametro bobina 60 mm.

Medium-capacity vertical reel, capable of holding approximately 45 meters of 1.5mm line. The sturdy plastic frame makes it lightweight, weighing only 100 grams, and it integrates a quick-release system into the frame, optimized for our Avatar handles. With this system, the reel can be quickly removed and reinserted. The system includes a lock button to prevent accidental reel release. The frame has two pre-drilled holes to accommodate a fish call device. The drag knob has a metal-threaded insert, and the removable handle, both ball-operated. The spool diameter is 60 mm.

MODEL	COLOR	CODICE	WEIGHT	CAPACITY
Seagull	Black	01.1S60.0B	100g	45m
Seagull	White	01.1S60.1W	100g	45m
Seagull	Yellow	01.1S60.2Y	100g	45m
Seagull	Red	01.1S60.3R	100g	45m
Seagull	Blue	01.1S60.4B	100g	45m
Seagull	Green	01.1S60.5G	100g	45m



COLIBRI

Mulinello verticale di piccola capienza, circa 25 metri di filo da 1.5 mm. interamente Costruito a CNC. manopola frizione con inserto filettato in metallo e maniglia estraibile entrambe con funzionamento a sfera. Diametro bobina 46 mm.

Small-capacity vertical reel, capable of holding approximately 25 meters of 1.5mm line. Entirely CNC machined. The drag knob has a metal-threaded insert, and the removable handle, both ball-operated. The spool diameter is 46 mm .

MODEL	COLOR	CODICE	WEIGHT	CAPACITY
-------	-------	--------	--------	----------



-Tre livelli con bloccaggio a sfera

-Three levels with ball lock

-Manopola frizione con 12 livelli di bloccaggio a sfera.

-Clutch knob with 12 levels of ball lock.



FALCO 57-77

Due modelli, da circa 50 metri a 100 metri di filo da 1.5 mm. Manopola frizione con inserto filettato metallico e maniglia estraibile entrambe con funzionamento a sfera. Due materiali per il supporto, in acciaio inox stampato o titanio, in entrambi i modelli la maniglia è in titanio. Diametro della bobina da 60 mm e da 77 mm.

Drag knob with metal-threaded insert and removable handle, both ball-operated. Two material options for the support: stamped stainless steel or titanium. In both models, the handle is made of titanium. Spool diameters available are 60 mm and 77 mm.



MODEL	COLOR	CODICE	WEIGHT	CAPACITY
FALCO 57 STEEL	BLACK	01.1F57.0B	166g	50m
	WHITE	01.1F57.1W	166g	50m
	YELLOW	01.1F57.2Y	166g	50m
	RED	01.1F57.3R	166g	50m
	BLUE	01.1F57.4B	166g	50m
	GREEN	01.1F57.5G	166g	50m

MODEL	COLOR	CODICE	WEIGHT	CAPACITY
FALCO 57 TITANIUM	BLACK	01.1F57.T0B	145g	50m
	WHITE	01.1F57.T1W	145g	50m
	YELLOW	01.1F57.T2Y	145g	50m
	RED	01.1F57.T3R	145g	50m
	BLUE	01.1F57.T4B	145g	50m
	GREEN	01.1F57.T5G	145g	50m



MODEL	COLOR	CODICE	WEIGHT	CAPACITY
FALCO 77 STEEL	BLACK	01.1F77.0B	205g	100m
	WHITE	01.1F77.1W	205g	100m
	YELLOW	01.1F77.2Y	205g	100m
	RED	01.1F77.3R	205g	100m
	BLUE	01.1F77.4B	205g	100m
	GREEN	01.1F77.5G	205g	100m

MODEL	COLOR	CODICE	WEIGHT	CAPACITY
FALCO 77 TITANIUM	BLACK	01.1F77.T0B	175.00g	100m
	WHITE	01.1F77.T1W	175.00g	100m
	YELLOW	01.1F77.T2Y	175.00g	100m
	RED	01.1F77.T3R	175.00g	100m
	BLUE	01.1F77.T4B	175.00g	100m
	GREEN	01.1F77.T5G	175.00g	100m



LEONARDO 77

Unico mulinello al mondo dotato di guida filo, l'avvolgimento è perfetto e veloce, grazie ad un sistema di trasmissione con vite senza fine e ruote dentate. Immaginate di aver arpionato un grosso pesce, in mare non è facile riavvolgere la sagola, con questo sistema lo potrete fare velocemente e non dovrete preoccuparvi, il filo si disporrà in file ordinate. Il supporto in Titanio contribuisce alla leggerezza del mulinello, la maniglia è in titanio ed estraibile, la manopola della frizione è a scatti con inserto filettato in metallo, entrambe con funzionamento a sfera. **Importante l'avvolgimento del filo va fatto in senso antiorario.**

The only reel in the world equipped with a line guide, ensuring perfect and fast winding, thanks to a transmission system with a worm screw and gears. Imagine spearing a large fish; rewinding the line in the sea isn't easy, but with this system, you can do it quickly, and you don't have to worry—the line will be arranged in neat rows. The titanium support contributes to the reel's lightness, and the handle is made of titanium and is removable. The drag knob is stepped, with a metal-threaded insert, both ball-operated.

It's important to wind the line counterclockwise.

MODEL	COLOR	CODICE	WEIGHT	CAPACITY
LEONARDO 77 TITANIUM	BLACK	01.2L77.0B	208g	100m
	WHITE	01.2L77.1W	208g	100m
	YELLOW	01.2L77.2Y	208g	100m
	RED	01.2L77.3R	208g	100m
	BLUE	01.2L77.4B	208g	100m
	GREEN	01.2L77.5G	208g	100m



SULA 68

Mulinello orizzontale di piccola capienza, circa 25 metri di filo da 1.5 mm. interamente Costruito a CNC. manopola frizione a sfera con inserto filettato in metallo e maniglia estraibile. Bobina D 68 mm.

Small-capacity horizontal reel, capable of holding approximately 25 meters of 1.5mm line. Entirely CNC machined. The drag knob is ball-operated with a metal-threaded insert, and the handle is removable. Spool diameter is 68 mm



MODEL	COLOR	CODICE	WEIGHT	CAPACITY
SULA 68	BLACK	01.3S68.0B	122G	25m



Contenuti generati dall'AI



ALBATROS HIGH LOW 80-100

Mulinello orizzontale in quattro modelli con bobine da 80 mm a 100 mm e due altezze differenti, capienze da 30 metri a 100 metri di filo da 1.5 mm a seconda dei modelli. Manopola frizione a sfera con inserto filettato metallico e maniglia estraibile, monta sia su legno che su fusti rotondi.

Horizontal reel available in four models with spool diameters ranging from 80 mm to 100 mm and two different heights, accommodating line capacities from 30 meters to 100 meters of 1.5 mm line, depending on the model. The drag knob is ball-operated with a metal-threaded insert, and the handle is removable. It can be mounted on both wooden surfaces and round barrels.

MODEL	COLOR	CODICE	WEIGHT	CAPACITY
ALBATROS 80 HIGH	BLACK	01.4A80.0B	137g	50m
	WHITE	01.4A80.1W	137g	50m
	YELLOW	01.4A80.2Y	137g	50m
	RED	01.4A80.3R	137g	50m
	BLUE	01.4A80.4B	137g	50m
	GREEN	01.4A80.5G	137g	50m



MODEL	COLOR	CODICE	WEIGHT	CAPACITY
ALBATROS 80 LOW	BLACK	01.5A80.0B	123g	30m
	WHITE	01.5A80.1W	123g	30m
	YELLOW	01.5A80.2Y	123g	30m
	RED	01.5A80.3R	123g	30m
	BLUE	01.5A80.4B	123g	30m
	GREEN	01.5A80.5G	123g	30m

MODEL	COLOR	CODICE	WEIGHT	CAPACITY
ALBATROS 100 HIGH	BLACK	01.6A10.0B	158g	100m
	WHITE	01.6A10.1W	158g	100m
	YELLOW	01.6A10.2Y	158g	100m
	RED	01.6A10.3R	158g	100m
	BLUE	01.6A10.4B	158g	100m
	GREEN	01.6A10.5G	158g	100m



MODEL	COLOR	CODICE	WEIGHT	CAPACITY
ALBATROS 100 LOW	BLACK	01.7A10.0B	142g	60m
	WHITE	01.7A10.1W	142g	60m
	YELLOW	01.7A10.2Y	142g	60m
	RED	01.7A10.3R	142g	60m
	BLUE	01.7A10.4B	142g	60m
	GREEN	01.7A10.5G	142g	60m

AVANT

Il supporto in acciaio inox si può fissare senza forare il legno, un asola predisposta entra nel retro del meccanismo utilizzando la stessa vite di bloccaggio. Il braccio è di facile estrazione, una manopola in acciaio lo comanda e può ruotare in diverse posizioni. Il supporto può integrare un call fish.

The stainless-steel support can be fixed without drilling the wood, a pre-arranged slot enters the back of the mechanism using the same locking screw. The arm is easy to extract, a steel knob controls it and can rotate in different positions. It features a built-in call fish

MODEL	CODICE	WEIGHT
SUPPORT AVANT ERMES	02.0010.00	26G



MODEL	CODICE	WEIGHT
BRACKET AVANT ERMES COMPLETE	02.0010.01	53G



MODEL	CODICE	WEIGHT
ARM AVANT CURVO	02.0003.06	28G



MODEL	CODICE	WEIGHT
SUPPORT AVANT CALL FISH	02.0011.00	46G



MODEL	CODICE	WEIGHT
BRACKET AVANT CALL FISH COMPLETE	02.0011.01	72G



BRACKET AVANT ERMES COMPLETE

02.0010.01

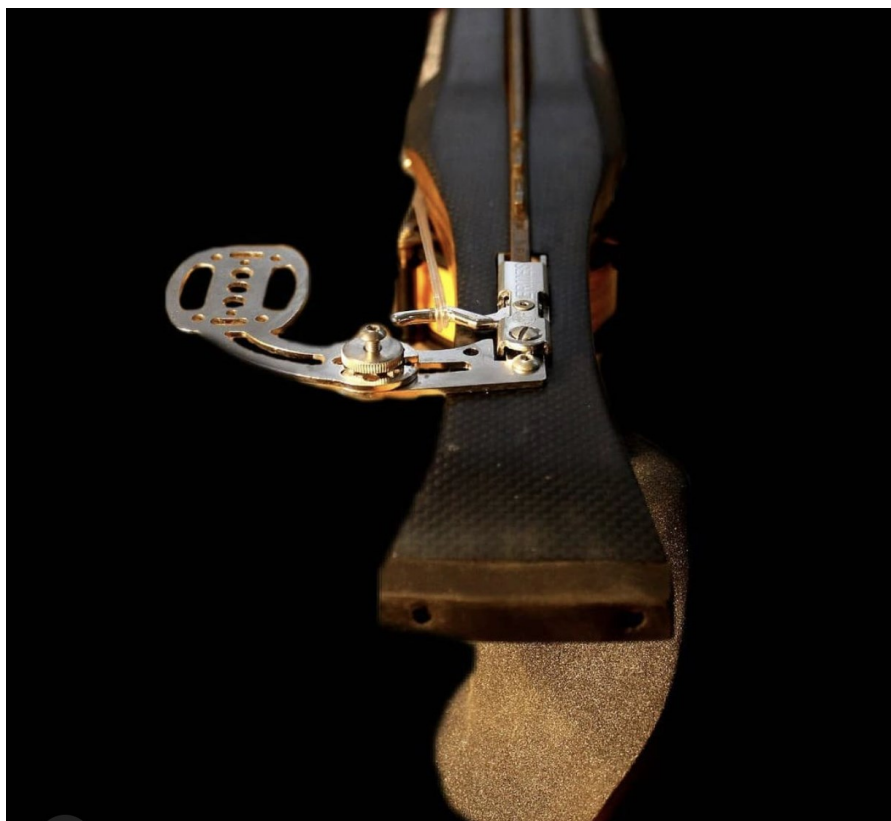

BRACKET AVANT CALL FISH COMPLETE

02.0011.01



REVOLUTION

Interamente costruita a cnc in pom c , equipaggia il nostro fucile Avatar, leggera, si estrae facilmente con l'aiuto di una molla e ruota con due punti di bloccaggio, uno di ripresa e l'altro per agevolare il caricamento del fucile rotazione in basso. Il supporto Go Pro è integrato.

Entirely cnc built in pom c, it equips our Avatar speargun, light, it is easily extracted with the help of a spring and rotates with two locking points, one for record and the other to facilitate loading of the speargun, rotation downwards .The support for GoPro is included



MODEL	CODICE	WEIGHT
ARM REVOLUTION PRO	02.0020.00	8G



MODEL	CODICE	WEIGHT
SUPPORT REVOLUTION	02.0021.00	11G

MODEL	CODICE	WEIGHT
BRACKET REVOLUTION COMPLETE	02.0021.01	18G



Primi a commercializzare il richiamo in acciaio per arbaleti in legno ed adatto per I nostri meccanismi, adesso affiancato da un altro modello universale interamente costruito a CNC in pom c , per arbaleti a tubo ed in legno grazie alla speciale base concava e parti piane per adattarsi a qualsiasi superficie, si adatta ai nostril arbalete della serie Avatar ed ai nostril mulinelli della serie Falco e Albatross . Il caratteristico tichetto emesso incuriosisce I pesci facilitando I avvicinamento.

First to commercialize the steel lure for wooden spearguns and suitable for our mechanisms, now joined by another universal model entirely CNC built in pom c, for tube and wooden spearguns thanks to the special concave base and flat parts to adapt to any surface, it adapts to our Avatar series spearguns and to our Falco and Albatross series reels. The characteristic ticking emitted intrigues the fish, facilitating the approach.

MODEL	CODICE	WEIGHT
CALL FISH SIREN	11.0014.07	10G



Tutti i nostri meccanismi adottano il sistema double roll, brevettato, ormai adottato dai migliori produttori di fucili, il grilletto allo sparo non si indurisce ed il rilascio dell'asta è dolce. Alcuni hanno il sistema a frizione più economico.

Costruito principalmente in acciaio inox AISI 316, il grilletto è costruito in **super lega** antiusura da noi formulata, il rullino di aggancio asta in 17-4ph, anch'esso antiusura.

Lo sgancia sagola è arrotondato, l'angolo di apertura è di 65 gradi. Testati con 550 kg di carico.

All our mechanisms adopt the double roller system, patented, and have a smooth shot, now adopted by the best speargun manufacturers, some have the lower cost friction system.

Mainly built in AISI 316 stainless steel, except for the trigger which is built in super alloy, anti-wear, and the rod coupling roller instead of 17-4ph steel, also anti-wear.

The line release is rounded and does not cut the line, the opening angle is 65 degrees. Load test 1000 shot for 550 kg!!



ERMES Super Alloy Trigger 550 Kg+

- Super Durable Trigger that is able to handle copious amount of stress
- Up to 1500 Shots without any wear on the pressure points
- Super Alloy Formula Patented by ERMES
- Tested in extreme conditions to ensure the longevity after tension, torsion and abrasion
- This Trigger is able to pull trough hundreds of shots at 150kg, 250kg, 350kg, 450kg, 550kg+
- Super Strong, Super Lasting, Super Smooth



MACHINE TEST LOAD

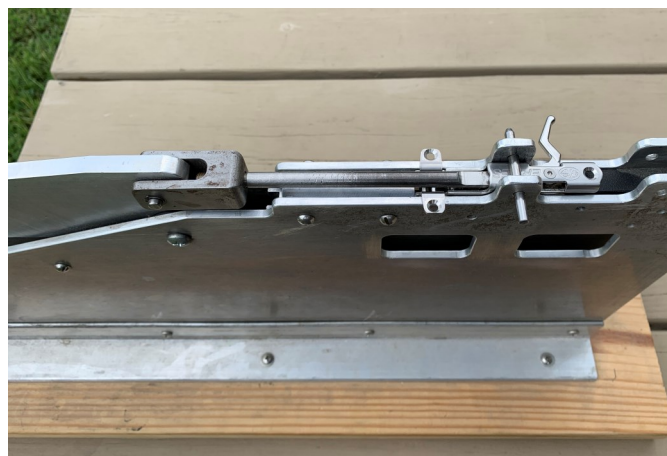

TRIGGERS BACK

Possibilità a scelta di grilletto corto e di grilletto lungo, di serie con sistema doppio roller ma anche in una versione economica con il sistema a frizione classico. Il montaggio è previsto con una spina di 3 mm laterale ed una vite dall'alto.

Possibility to choose between short trigger and long trigger standard with double roller system but also in an economic version with the classic clutch system. The assembly is foreseen with a 3 mm lateral pin and a screw from the top.

MODEL	CODICE	WEIGHT
BACK DOUBLE ROLL	00.0001.00	76.00G



TRIGGERS EVO BACK

Stesse dimensioni e caratteristiche del modello Back , cambia invece il montaggio che verrà effettuato dall'alto con tre viti in linea al piano superiore della scatola del meccanismo.

Same dimensions and features as the Back model changes instead the assembly will be carried out from the top with three screws in line on the upper floor of the box.

MODEL	CODICE	WEIGHT
EVO BACK DOUBLE ROLL	00.0002.00	81.00G



TRIGGERS FUTURE

Stesse dimensioni e caratteristiche del modello Back. il box è piegato con un sistema che permette di evitare saldature nelle ali per il fissaggio delle viti, il fissaggio sarà completato da una terza vite nel retro della scatola. Disponibile in color Oro e acciaio.

Same dimensions and features as the Back model. the box is folded with a system that allows to avoid welding in the wings for fixing the screws, the fixing will be completed by a third screw in the back of the box. Also available in gold color.

MODEL	CODICE	WEIGHT
DOUBLE ROLL	00.0003.00	77.00G



MODEL	CODICE	WEIGHT
DOUBLE ROLL GOLD	00.0003.02	77.00G

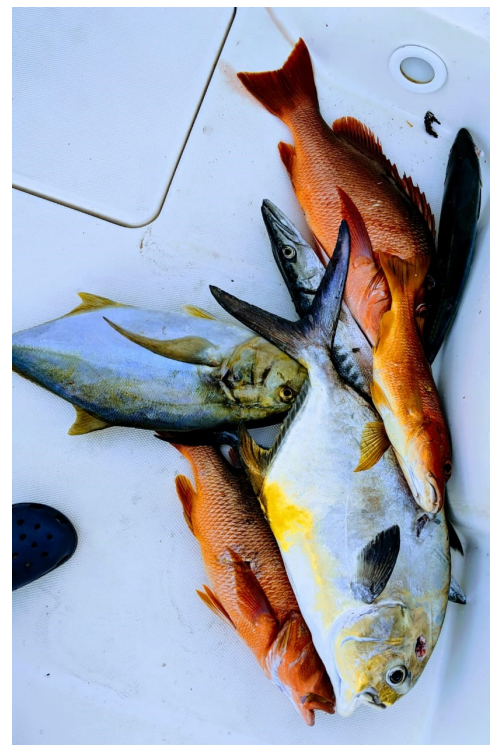

TRIGGERS WINGS

Derivato dal modello future, di cui mantiene tutte le caratteristiche, è il migliore meccanismo da noi prodotto, con carichi di lavoro importanti riesce tranquillamente ad operare con 600 kg di carico.

Derived from the future model of which it retains all the characteristics. it is the best mechanism we produce with heavy workloads it can easily operate with a load of 600 kg.

MODEL	CODICE	WEIGHT
WING DOUBLE ROLL	00.0004.00	95.00G
DOUBLE ROLL GOLD	00.0004.02	95.00G



TRIGGERS AVATAR

Meccanismo leggero box da 1.5 mm, sgancia sagola piccolo e grilletto corto, componenti in acciaio aisi 316 , equipaggia il nostro fucile omonimo , si può montare con 2 spine laterali [possibile fare richiesta della sicura in nylon caricato in vetro. Disponibile in colore oro.

Lightweight 1.5 mm box mechanism, small line release and short trigger, components in AISI 316 steel, equips our speargun , can be mounted with 2 lateral pins [you can request the safety glass loaded nylon. Gold colour available.

MODEL	CODICE	WEIGHT
AVATAR DOUBLE ROLL	00.0013.00	92.00G
AVATAR DOUBLE ROLL GOLD	00.0013.01	92.00G



BLOCKS FOR INVERT SYSTEM



MODEL	CODICE	WEIGHT
BLOCKS 2 SLIDING PAIR TITANIUM	03.0032.10	14G
BLOCKS 2 CERAMIC TITANIUM	03.0032.20	19G

MODEL	CODICE	WEIGHT
BLOCKS 4 SLIDING TITANIUM	03.0034.10	28G
BLOCKS 4 CERAMIC TITANIUM	03.0034.20	33G

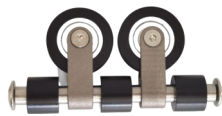

MODEL	CODICE	WEIGHT
BLOCKS 6 SLIDING TITANIUM	03.0036.10	33G
BLOCKS 6 CERAMIC TITANIUM	03.0036.20	38G

MODEL	CODICE	WEIGHT
BLOCKS 8 SLIDING TITANIUM	03.0036.10	33G
BLOCKS 8 CERAMIC TITANIUM	03.0036.20	38G



MODEL	CODICE	WEIGHT
BLOCKS HARD 3 SLIDING PAIR	03.0023.00	34G
BLOCKS HARD 3 CERAMIC PAIR	03.0023.01	40G

MODEL	CODICE	WEIGHT
BLOCKS HARD 5 SLIDING	03.0025.00	36G
BLOCKS HARD 5 CERAMIC	03.0025.01	42G



MODEL	CODICE	WEIGHT
BLOCKS HARD 7 SLIDING	03.0027.00	43G
BLOCKS HARD 7 CERAMIC	03.0027.01	49G

MODEL	CODICE
BLOCK PLASTIC 2 SLIDING	03.0022.18
BLOCK PLASTIC 2 CERAMIC	03.0022.22



MODEL	CODICE
BLOCKS PLASTIC 6 SLIDING	03.0622.18
BLOCKS PLASTIC 6 CERAMIC	03.0622.22



KIT ROLLER MONO

MODEL	CODICE	WEIGHT
<u>KIT ROLLER MONO SLIDING</u>	<u>03.0000.00</u>	<u>95G</u>

Kit mono roller base is composed as follows:

- 1 Pairs of pulleys 16 x 28 Sliding 16 mm;
- 1 Axis 6 x 55 with 4 screws M4 x 6
- 1 Stopper tube 110 with 3 screws
- 1 Pair banks with 4 screws
- 1 Hook croco



MODEL	CODICE	WEIGHT
<u>KIT ROLLER MONO CERAMIC</u>	<u>03.0000.01</u>	<u>100G</u>

Kit mono roller base is composed as follows:

- 1 Pairs of pulleys 16 x 28 Ceramic 16 mm;
- 1 Axis 6 x 55 with 4 screws M4 x 6
- 1 Stopper tube 110 with 3 screws
- 1 Pair banks with 4 screws
- 1 Hook croco
- 1 Anchor line

KIT ROLLER DOUBLE

MODEL	CODICE	WEIGHT
<u>KIT ROLLER DOUBLE SLIDING</u>	<u>03.0007.00</u>	

Kit mono roller base is composed as follows:

- 4 Pairs of pulleys 16 x 28 Sliding 16 mm;
- 2 Axis 6 x 82 with 4 screws M4 x 6
- 1 Stopper tube 170 with 5 screws
- 1 Pair banks with 4 screws
- 1 Anchor line



MODEL	CODICE	WEIGHT
<u>KIT ROLLER DOUBLE CERAMIC</u>	<u>03.0007.00</u>	

Kit mono roller base is composed as follows:

- 4 Pairs of pulleys 16 x 28 Ceramic 16 mm;
- 2 Axis 6 x 82 with 4 screws M4 x 6
- 1 Stopper tube 170 with 5 screws
- 1 Pair banks with 4 screws
- 1 Anchor line



PULLEY

MODEL	CODICE	WEIGHT
<u>CERAMIC BEARING</u>	<u>04.0626.00</u>	<u>3G</u>



MODEL	CODICE	WEIGHT
<u>PULLEY D18H5</u>	<u>04.1805.00</u>	<u>3G</u>



MODEL	CODICE	WEIGHT
<u>PULLEY D18H16</u>	<u>04.1816.00</u>	<u>5G</u>



MODEL	CODICE	WEIGHT
<u>PULLEY D22H5 CERAMIC</u>	<u>04.2205.01</u>	<u>10G</u>



MODEL	CODICE	WEIGHT
<u>PULLEY D28H16</u>	<u>04.2816.00</u>	<u>21G</u>



MODEL	CODICE	WEIGHT
<u>PULLEY D28H16 CERAMIC</u>	<u>04.2816.001</u>	<u>26G</u>



MODEL	CODICE	WEIGHT
<u>PULLEY D30H08</u>	<u>04.3008.00</u>	<u>14G</u>



MODEL	CODICE	WEIGHT
<u>PULLEY D30H11</u>	<u>04.3011.00</u>	<u>16G</u>



MODEL	CODICE	WEIGHT
<u>PULLEY D30H11 CERAMIC</u>	<u>04.3011.01</u>	<u>20G</u>



MODEL	CODICE	WEIGHT
<u>PULLEY D36H06 CERAMIC</u>	<u>04.3606.00</u>	<u>20G</u>



MODEL	CODICE	WEIGHT
<u>PULLEY D36H08</u>	<u>04.3608.00</u>	<u>20G</u>



MODEL	CODICE	WEIGHT
<u>PULLEY D36H16</u>	<u>04.3616.00</u>	<u>34G</u>



MODEL	CODICE	WEIGHT
<u>PULLEY D40H08</u>	<u>04.4008.00</u>	<u>25G</u>



MODEL	CODICE	WEIGHT
<u>PULLEY D60</u>	<u>04.6016.00</u>	<u>45G</u>



Profilo non lineare progettato per attutire il colpo di frusta allo sparo . Dotato di numerosi alleggerimenti, ha due nasini ferma filo . Fornito con viti autofilettanti 2,9 x 13

Artiglio 60: spessore 2 mm lunghezza 60 mm.

Non-linear profile designed to cushion whiplash when shot. Equipped with numerous lightnings, it has two thread stop noses. Supplied with 2.9 x 13 self-tapping

MODEL	CODICE	WEIGHT
STOPPER ARTIGLIO 60	07.0060.00	28G



Tagliato da un tubo con diametro esterno 16 mm e interno 13 mm provvisto di alleggerimenti dal design pulito, evita di tagliare il filo in battuta con lo stopper.

Cut from a tube with outer diameter 16 mm and internal 13 mm provided with many lightening clean design, avoids cuts the line in abutment with the stopper.

MODEL	CODICE	WEIGHT
STOPPER TUBE TITANIUM 110	07.1110.00	26G



MODEL	CODICE	WEIGHT
STOPPER TUBE 170	07.1170.00	38G



Coppia sponde con naso passa filo, hanno foro centrale per albero da 6 mm . Con 4 viti autofilettanti

Couple bank with nose, they have a central hole for a 6 mm shaft and are

MODEL	CODICE	WEIGHT
BANKS STRAIGHT	08.3672.00	17G



MODEL	CODICE	WEIGHT
AXIS M4X6X38	06.0406.38	11.00G
AXIS M4X6X48	06.0406.48	12.00G
AXIS M4X6X50	06.0406.50	13.00G
AXIS M4X6X55	06.0406.55	15.00G
AXIS M4X6X60	06.0406.60	16.00G
AXIS M4X6X65	06.0406.65	17.00G
AXIS M4X6X70	06.0406.70	18.00G
AXIS M4X6X82	06.0406.82	20.00G

HOOK



MODEL	CODICE	WEIGHT
HOOK PRET. EAGLE MONO	09.0026.00	13.00G
HOOK EAGLE DOUBLE	09.0058.00	35.00G

MODEL	CODICE	WEIGHT
HOOK CROCOLOCK MONO	09.0016.00	14.00G
HOOK CHOCO DOUBLE	09.4424.00	34.00G



MODEL	CODICE	WEIGHT
HOOK CROCO SUPORT REEL	09.4020.00	58.00G



SPEARGUNS BODY ACCESSORIES

MODEL	CODICE	WEIGHT
<u>HILT 120</u>	<u>10.0000.004</u>	<u>20G</u>



MODEL	CODICE	WEIGHT
<u>HILT PIANE LARGE</u>	<u>10.0001.00</u>	<u>12G</u>



MODEL	CODICE	WEIGHT
<u>HILT SMALL</u>	<u>10.0002.00</u>	<u>25G</u>



MODEL	CODICE	WEIGHT
<u>HILT S</u>	<u>10.0000.01</u>	<u>19G</u>



MODEL	CODICE	WEIGHT
<u>ANCHOR LINE</u>	<u>10.0004.002</u>	<u>8G</u>



MODEL	CODICE	WEIGHT
<u>GUIDE LINE</u>	<u>10.0005.00</u>	<u>8G</u>



MODEL	CODICE	WEIGHT
<u>KIT GUIDE LINE</u>	<u>11.0000.00</u>	<u>14G</u>



MODEL	CODICE	WEIGHT
<u>KIT BALLAST COMPAR.</u>	<u>11.0001.10</u>	<u>33G</u>



MODEL	CODICE	WEIGHT
<u>KIT ACCESSORIES</u>	<u>11.0002.00</u>	<u>64G</u>



MODEL	CODICE	WEIGHT
<u>KIT TRIGGER FIXING</u>	<u>11.0009.00</u>	<u>7G</u>



MODEL	CODICE	WEIGHT
<u>KIT FIXING 3 SCREWS</u>	<u>11.0010.00</u>	<u>13G</u>



MODEL	CODICE	WEIGHT
<u>KIT REEL FIXING</u>	<u>11.0012.01</u>	<u>9G</u>





FIXING

SPRING DOUBLE TORSION

PRICE: 2.00



KNURLED KNOB

PRICE: 1.



HEX NUT

SIZE
M3XH4
M4XH5



HEXAGON BOTTOM

SIZE

M3XL6
M3XL10
M4XL8
M4XL12
M4XL16
M4XL20
M4XL25
M4XL50
M4XL60



HEXAGON SCREW

SIZE

M3XL6
M3XL8
M3XL10
M4XL14
M4XL16
M4XL20
M4XL25



SCREW

SIZE

2,9XL13
3,5XL9,5
3,5XL13
3,5XL19
3,5XL20
4,5XL35



FIXING PIN

SIZE

D3XL9.5
D3XL6
D3XL10
D3XL11.6
D3XL14
D4XL10
D5XL10
D5XL14
D5XL14.7



ELASTIC PIN

SIZE

2,5X10
2,5X12
2,5X14
2,5X16
3X10
3X16



THREAD SPACER

SIZE

M3XL9.9
M3XL10.7
M3XL12



POLIERS

SIZE

M4XL6
M4XL12



SCREWS

SIZE

2,9XL13
3,5XL13
3,5XL19



TITANIUM KNIVES

- ◆ Da una nostra idea nascono una serie di coltelli con design ricercato ed innovativo , con i temi, aria (EAGLE) simbolo aquila stilizzata.
- ◆ Mare (SEA) simbolo tridente stilizzato.
- ◆ Terra (GLADIO) simbolo Elmo guerriero stilizzato.
- ◆ Lama Costruita interamente in Titanio di spessore 4 mm, un lato affilato ed un altro seghettato.
- ◆ Estrattore per aste integrato nel design in optional manico in pom Bianco o Nero.
- ◆ Fodero in Pom c , con il coperchio in acciaio inox satinato con bloccaggio doppia sfera.
- ◆ Interamente costruite con macchine a controllo numerico .
- ◆ From our idea, a series of knives with a refined and innovative design are born, with the themes, air (EAGLE), stylized eagle symbol.
- ◆ Sea (SEA) stylized trident symbol.
- ◆ Earth (GLADIO) symbol Stylized warrior helmet.
- ◆ Blade Made entirely of 4 mm thick Titanium, one side sharp and the other serrated.
- ◆ Rod extractor integrated into the design in optional White or Black pom handle.
- ◆ Pom c sheath, with satin stainless steel lid with double ball locking.
- ◆ Entirely built with numerical control machines.



EAGLE

- ◆ Lama in Titanio di 4 mm di spessore x 173 mm di lunghezza totale con un lato seghettato.
- ◆ Disegno stilizzato occhi e becco di aquila estrattore di aste.
- ◆ Fodero realizzato in plastica pom e coperchio in acciaio inox satinato.
- ◆ Bloccaggio a sfere.
- ◆ Predisposizione fissaggio cinturone e braccio.
- ◆ 4 mm thick Titanium blade ,total length 173 mm with a serrated side.
- ◆ Stylized drawing eyes and beak of an eagle shaft extractor.
- ◆ Sheath made of plastic pom and lid in satin stainless steel.
- ◆ Ball locking.
- ◆ Predisposition for fixing belt and arm.

MODEL	CODICE	WEIGHT	DIMENSION
TITANIUM EAGLE KNIFE	20.0000.00		173 mm TOTAL

MODEL	CODICE	WEIGHT	DIMENSION
TITANIUM EAGLE KNIFE BLACK	20.0000.01		173 mm TOTAL

MODEL	CODICE	WEIGHT	DIMENSION
TITANIUM EAGLE KNIFE WHITE	20.0000.02		173 mm TOTAL



SEA KNIFE

- ◆ Lama in Titanio di 4 mm di spessore x 145 mm di lunghezza totale con un lato seghettato.
- ◆ Disegno stilizzato Tridente con estrattore di aste.
- ◆ Fodero realizzato in plastica pom e coperchio in acciaio inox satinato.
- ◆ Bloccaggio a sfere.
- ◆ Predisposizione fissaggio cinturone e braccio.
- ◆ 4 mm thick Titanium blade ,total length 145 mm with a serrated side.
- ◆ stylized trident drawing with shaft extractor.
- ◆ Sheath made of plastic pom and lid in satin.
- ◆ Stainless steel.
- ◆ Ball locking.
- ◆ Predisposition for fixing belt and arm.

MODEL	CODICE	WEIGHT	DIMESION
TITANIUM SEA KNIFE	20.0001.00		144 mm total



Le sagole multiuso Avatar X 8 e X 16 da 1.2 mm fino a 2.3 mm sono indicate per collegare l'asta alla sagola del mulinello, per legare le ogive agli elastici, ma anche possono essere usate come unica sagola grazie al suo ridotto volume la dove necessita incrementare la capienza dei mulinelli.

- 100% HMWPE ad alto modulo polietilene con rivestimento in Resina Epossidica
- Elevato carico di rottura
- Resistente all'usura
- Resistente all'abrasione
- Resistente ai raggi UV
- Galleggiante
- Bobine da 50 metri in continuo fino a 100 m

The multipurpose lines Avatar X 8 and X 16 from 1.2 mm up to 2.3 mm are indicated to connect the shaft to the line of the reel, to tie the ogives to the rubber bands, but they can also be used as a single line thanks to its reduced volume where it is necessary to increase the capacity of the reels

- 100% HM WPE high modulus polyethylene with eposidic resin coating.
- High breaking load
- Wear resistant
- Resistant to abrasion
- UV resistant
- Float
- Package in 50 m coils, until 100 m in continuous

CODICE	MODELO	BREAKING STRENGHT
14.1650.OB	X16 Line 1.9 mm BLUE COIL 50m	240kg
14.1650.OG	X16 Line 1.9 mm DARK GREEN COIL 50m	240kg
14.1650.FL	X16 Line 1.9 mm FLOURO GREEN COIL 50m	240kg
14.1650.OR	X16 Line 1.9 mm RED COIL 50m	240kg
14.1650.BC	X16 Line 1.9 mm BLACK COIL 50m	240kg
14.1650.OW	X16 Line 1.9 mm WHITE COIL 50m	240kg



Due spessori di monofilo 1.65 di colore verde , morbido e flessibile e nero da 1.9 mm piu rigido, per condizioni estreme, entrambi vengono forniti con crimp di collegamento , ideali per collegare le aste alla sagola del mulinello o al vostro galleggiante .

- Elevato carico di rottura
- Resistente all'usura
- Resistente all'abrasione
- Resistente ai raggi UV

Two thicknesses of 1.65 monofilament green, soft and flexible 1.9 mm more rigid, for extreme conditions, both are supplied with connection crimp, ideal for connecting the shaft to the reel line or to your float.

- High breaking load
- Wear resistant
- Resistant to abrasion
- UV resistant

CODICE
MODELLO

14.165G.20	1.65 mm green 20 meter 10 crimps
14.165G.33	1.65 mm green 33 meter 16 crimps



MINIMAL

- ◆ **Maschera a volume estremamente ridotto.**
- ◆ **Telaio inserito per fusione.**
- ◆ **Naso preformato.**
- ◆ **Cinturino con fibbia regolabile.**
- ◆ **Vetro temperato.**
- ◆ **Silicone esterno opaco.**
- ◆ **Adatta per free dive ,spearfishing, snorkeling.**
- ◆ **Extremely low volume mask.**
- ◆ **Frame inserted by fusion.**
- ◆ **Preformed nose.**
- ◆ **Strap with adjustable buckle.**
- ◆ **Tempered glass.**
- ◆ **Matt external silicone.**
- ◆ **Suitable for free dive ,spearfishing, snorkeling**

**CODICE**30.0000.00

ACTION MASK

- ◆ **Maschera in silicone in vari modelli anche con attacco Action Cam integrato.**
 - ◆ **Vetro temperato.**
 - ◆ **Silicone di qualita, per una alta visibilita ed aderenza.**
 - ◆ **Adatta per pesca sub , snorkeling e scuba diving**
- ◆ **Silicone mask in various style even with integrated Action Cam attachment.**
 - ◆ **Tempered glass.**
 - ◆ **Quality silicone, for high visibility and adherence.**
 - ◆ **Suitable for spearfishing, snorkeling and scuba diving**



CODICE

30.0010.00



BIG ACTION

- ◆ **telaio inserito per fusione.**
- ◆ **Naso preformato.**
- ◆ **Cinturino con fibbia regolabile.**
- ◆ **Vetro temperato.**
- ◆ **Adatta , scuba diving, snorkelling.**
- ◆ **frame inserted by fusion.**
- ◆ **Preformed nose.**
- ◆ **Strap with adjustable buckle.**
- ◆ **Tempered glass.**
- ◆ **Suitable ,scuba diving, snorkeling.**

**CODICE**30.0020.00

VISION MASK

- ◆ Maschera in silicone in vari modelli anche con attacco Action Cam integrato.
- ◆ Vetro temperato.
- ◆ Silicone di qualità, per una alta visibilità ed aderenza.
- ◆ Adatta per pesca sub , snorkeling e scuba diving
- ◆ Silicone mask in various style even with integrated Action Cam attachment.
- ◆ Tempered glass.
- ◆ Quality silicone, for high visibility and adherence.
- ◆ Suitable for spearfishing, snorkeling and scuba diving



<u>CODICE</u>	<u>MODEL</u>
<u>30.0010.01</u>	<u>VISION CAM</u>
<u>30.0010.02</u>	<u>VISION CAMO BLUE</u>
<u>30.0010.03</u>	<u>VISION CAMO BROWN</u>

- ◆ Snorkel extrasoft in silicone colore verde mimetico.
- ◆ Snorkel soft in silicone arancione alta visibilita.
- ◆ Snorkel soft in silicone nero.
- ◆ Morso anatomico in silicone.
- ◆ Anallergico per un prolungato utilizzo.
- ◆ Passante fissa tubo.
- ◆ Extrasoft snorkel in camouflagage green silicone.
- ◆ Soft snorkel in high visibility orange silicone.
- ◆ Soft black silicone snorkel.
- ◆ Anatomical silicone bite.
- ◆ Hypoallergenic for prolonged use.
- ◆ Fixed tube loop.

MODEL	CODICE
<u>Green Silicon snorkel</u>	<u>30.1000.0G</u>
<u>Orange Silicon snorkel</u>	<u>30.1000.0O</u>
<u>Black Silicon snorkel</u>	<u>30.1000.0B</u>
<u>Blue Silicon snorkel</u>	<u>30.1000.0S</u>



AVATAR Carbon

- 1) Pala fibra 100% carbonio Hi tech
- 2) Lavorazione ad alta temperatura , pressione e sottovuoto priva di difetti.
- 3) Lo spessore variabile per tutta la lunghezza della pala assicura una distribuzione ottimale della spinta idrodinamica.
- 4) Modello (M) 705 x 195 mm, totale 833 mm , angolo pala 30 gradi
- 5) La scarpetta rigida sotto e confortevole assicura una pinneggiata fluida e ottimale. L attacco pala-longheroni corto a clip, e l innesto a 2 viti, assicurano una perfetta tenuta della pala, rendendo inutile l uso di colle di fissaggio.
- 6) Bordini in pvc marino color Rosso.
- 8) Misure scarpetta : 41-42, 43-44, 45-46

- 1) 100% Hi-Tech fiber carbon composite blades
- 2) High temperature/pressure vacuum flawless manufacturing
- 3) All length variable thickness assures optimum hydrodynamic thrust
- 4) Model (M) 705 x 195 mm, total 833 mm, blade angle 30 degrees
- 5) The rigid and comfortable foot pocket ensures fluid and optimal kicking. The short clip-onblade-side tendon connection and the 2-screw fitting ensure perfect blade holding, making the use of fixing glue unnecessary.
- 6) Marine PVC guiderails in red color.
- 7) Footpocket sizes: 41-42, 43-44, 45-46.



MODEL	CODE	MEASURE	HARDNESS	DEGREE
Carbon fins Deep AVATAR	31.4142.CM	41-42	medium	30
Carbon fins Deep AVATAR	31.4142.CM	43-44	medium	30
Carbon fins Deep AVATAR	31.4142.CM	45-46	medium	30
Carbon Blade Deep Avatar	31 .0000.CM	833x195	medium	30
Foot Pocket C	31.4142.01	41-42		
Foot Pocket C	31.4344.03	43-44		
Foot Pocket C	31.4546.05	45-46		



DEN

- ◆ Battery type : multiple possibilities 26650 or 18650 or 3 AAA ,
- ◆ 50,000 Hours, which eliminates the trouble of replacing the lamp
- ◆ Led XHP70 25 W , 3.7 V ,2500 Lumen max , 6500 k
- ◆ Mode : strong light, weak light, fast flash, long press 4 sec SOS
- ◆ Body aluminum 6061 alloy IP68 50—80 meter Deep , magnetic switch
- ◆ Size 130x44x36 mm, weight : gr 218
- ◆ Bag : flashlight, hand strap, 26650 conversion sleeve, charger , battery 18650, for 3 AAA
- ◆ Puoi usare batterie ricaricabili 26650 , 18650 , o 3 normali AAA .
- ◆ 50,000 ore di durata , che elimina il problema del cambio di lampada.
- ◆ Led XHP70 25 W , 3.7 V ,2500 Lumen max , 6500 k
- ◆ Mode : luce forte, luce debole, luce veloce, e SOS premendo per 4 secondi.
- ◆ Corpo di alluminio 6061 , IP68 50—80 metri interruttore magnetico.
- ◆ Misura 130x44x36 mm, peso : gr 218
- ◆ valigetta : torcia, lacciolo, adattatore per 26650 ,caricabatterie , batteria ricaricabile, adattatore per 3 pile AAA

Product Structure



CODICE

MODEL

34.XP70.01

FLASHLIGHT DEN